

TORQUEEDO
STARNBERG.GERMANY

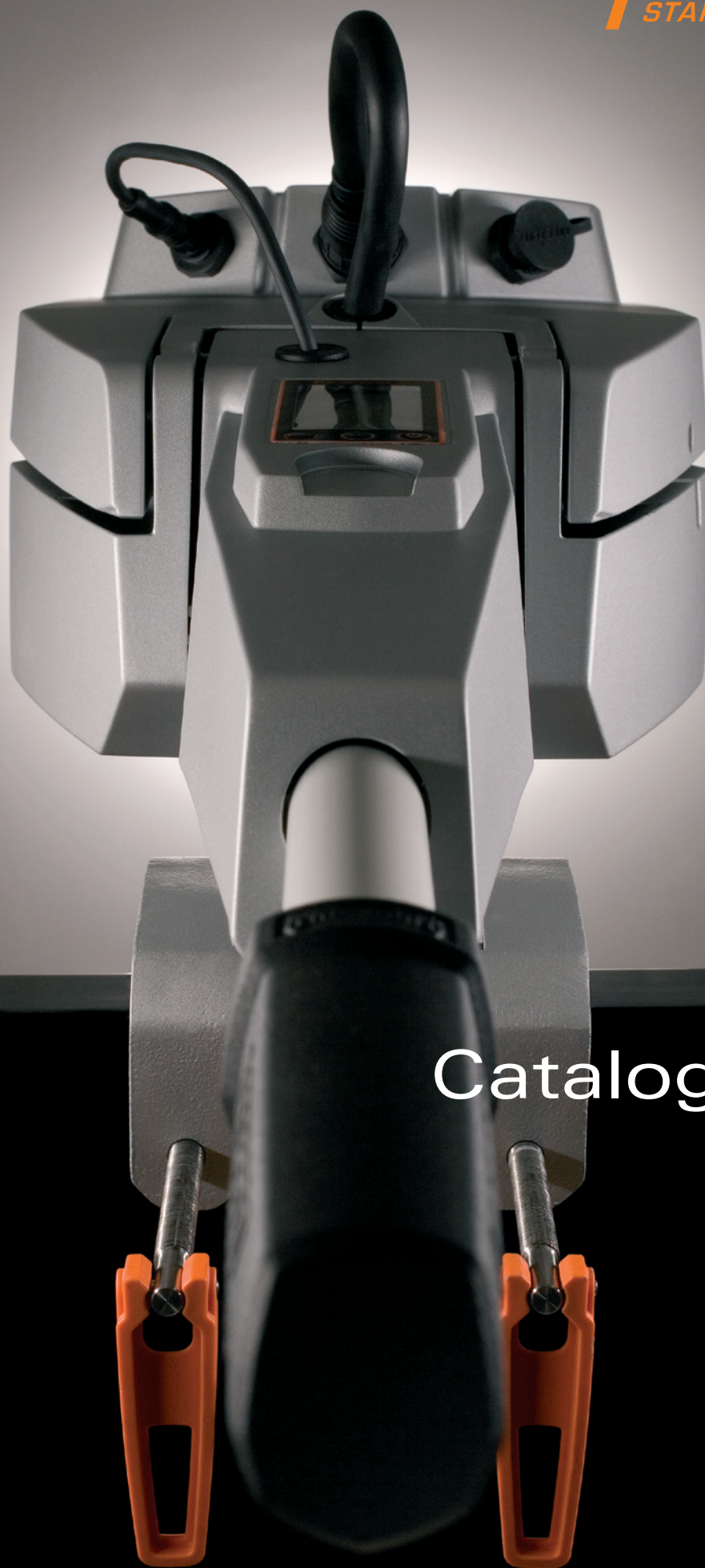

Catalog 2010

There are 2 simple principles behind any Torqeedo product: Superior technology and revolutionary benefit.

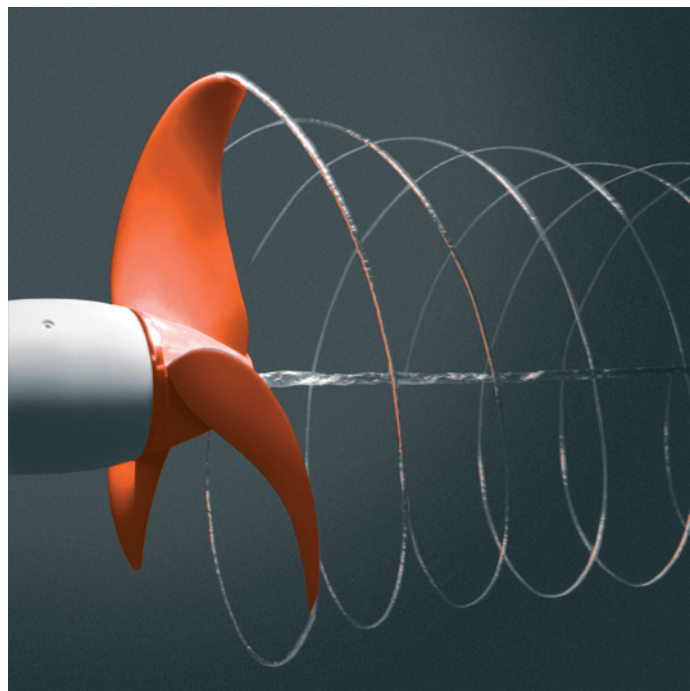

Unrivalled technology

Recent developments in various fields of technology such as electronics, material, and battery technology, have provided great potential for improving electric drives:

- Commutation, or the current flow through the motor coils, which turns a motor, can be controlled by small, extremely efficient electronic systems. This means mechanical contacts (brushes) are no longer necessary and gives us a new scope in motor design.
- Rare earth magnets demonstrate much greater field strength than traditional hexaferrite magnets and have become more affordable for use in the leisure industry.
- Lithium-battery technology is continually expanding into many aspects of today's technology.

Torqeedo is the first and so far the only company in the marine industry that fully exploits the potential of these new technologies in the development of a new generation of motors: high-tech, powerful, lightweight and clean.

Unrivalled efficiency

Why doesn't everybody use electric propulsion?

It is not due to the motors: electric motors are superior over internal combustion motors in every power class: they are smaller, lighter, cheaper to produce and easier to maintain.

It is due to battery technology: gasoline has 600 times the energy density compared to a standard lead-gel or AGM battery. And even compared to latest lithium-battery technology the energy density of gasoline is 100 times superior.

So the question for electric propulsion is: how much propulsive power do you get from a limited supply of battery energy?

Torqeedo outboards run for up to 16 nautical miles on the energy equivalent to 0.7 oz. of gasoline. In other words: our motors run for more than 3,000 miles on the energy equivalent to 1 gallon of gasoline.

Currently, no one in the industry even comes close to this performance.



What is ecologically right can be economically right as well. Oh, and at higher comfort of course.

There are plenty of situations in which you can't avoid pollution. Running a small outboard is definitely no longer one of them.

You can improve your ecological footprint without losing performance and at greater comfort. And in the long run, it is even cheaper than running a gasoline outboard. Too good to be true?

At Torqeedo we see it as our mission to offer cutting edge technology products that combine performance, responsibility, comfort and economical advantage.

You do have an alternative.

Contents

Propulsive power and overall efficiency.....	Page 4
Torqeedo technologies.....	Page 6
Ultralight 402.....	Page 8
Travel 503/1003 NEW.....	Page 10
Travel 401/801.....	Page 12
Cruise 2.0 (tiller control).....	Page 14
Cruise 2.0 R/4.0 R.....	Page 16
Power 26-77.....	Page 18
CIGS Solar Charger 62 W.....	Page 20
AGM batteries.....	Page 21
Technical data.....	Page 22
Ordering information.....	Page 23

Propulsive power and overall efficiency

What you should know about the performance of a boat drive

In commercial shipbuilding, the performance of a motor has been measured for almost 100 years by how much power it actually delivers for propelling the vessel. This power is **called propulsive power**. It is physically defined as thrust acting on the vessel times speed, and can be expressed in watts or horsepower.

Also for recreational boating, propulsive power is the most meaningful performance indicator, as it measures the power actually delivered to move the boat. Yet, you won't find figures for propulsive power in catalogs from other manufacturers of electric or gas outboards. Instead, you will find other figures that are less informative and don't allow to compare different motor types:

- Typically, electric outboard manufacturers specify their **input power** in watts. This is an important indicator of consumption, but doesn't state how much of the power consumed is supplied to the boat. Describing a motor by input power alone is about as useful as measuring the engine performance of a car by its fuel consumption.
- Electric trolling motor suppliers provide power ratings in terms of static thrust, typically specified in pounds. **Static thrust** describes the ability of a motor to move a boat from speed zero to an infinitely slow moving speed. Taken in isolation, static thrust is unsuitable as a measure of the power of an outboard. As described above, the propulsive power of a motor is defined physically as thrust times speed, so when the speed is zero, the propulsive power is also zero. From our perspective, focusing on static thrust data as performance indicators disguises the comparison of electric motors versus horsepower ratings of gas outboards.
- Manufacturers of internal combustion outboards do not state the propulsive power of their motors either. Instead they give the **shaft power** measured at the propeller shaft. Losses due to heat, incomplete combustion, friction etc. have already been accounted for at this point. However, the shaft power does not account for propeller losses, which can vary between 30% and 78% for different motor types. Therefore, shaft power is only, to a very restricted degree, useful for comparing different drive types.

Just like manufacturers in commercial shipbuilding, at Torqeedo, we always go by the propulsive power of our outboards, i.e. the power actually delivered to the boat after deduction of all losses, including propeller losses. There are two reasons. First, it creates transparency so we can compare



our motors properly with combustion outboards, which have significantly higher losses in the propeller. Second, measuring propulsive power is the only way to ensure that we produce the world's most efficient outboards.

Another important index apart from propulsive power is **overall efficiency**. It describes the efficiency with which a drive system converts the supplied energy into propulsive power, and is calculated from the relation between input power consumed and propulsive power. For internal combustion outboards, overall efficiency is interesting; for electric outboards, overall efficiency is key: As batteries have only a small fraction of the energy density compared to gas, the battery capacity is almost always the limiting factor for an electric motor.

Efficient use of the battery supply is decisive for how much power and range an electric drive can get out of a battery bank. Double overall efficiency means double range or higher speed. Typically, electric trolling motors have overall efficiency rates of around 20%. That means 80% of the input power is lost in the motor, cables and propeller. Very expensive, heavy and powerful electric drive systems that use conventional technology come with overall efficiency rates of 30-35%. Torqeedo drives give you efficiency rates between 44% and 51%, making them today's leading technology. Internal combustion outboards are especially inefficient, particularly in displacement travel. In this area more than 80% of the energy stored in the gas never reaches the shaft, but is lost in the engine. Of this remaining shaft power, another 75% then gets lost in the propeller which results in an overall efficiency rate for internal combustion outboards of approximately 5%. In other words, as much as 95% of the energy contained in the gas is not converted into propulsion, but lost to inefficiency.

Our specifications of propulsive power and overall efficiency rates have been confirmed not only in tests by independent publications, but also by a certified test institute in a towing tank test.

Performance indicators of boat drives

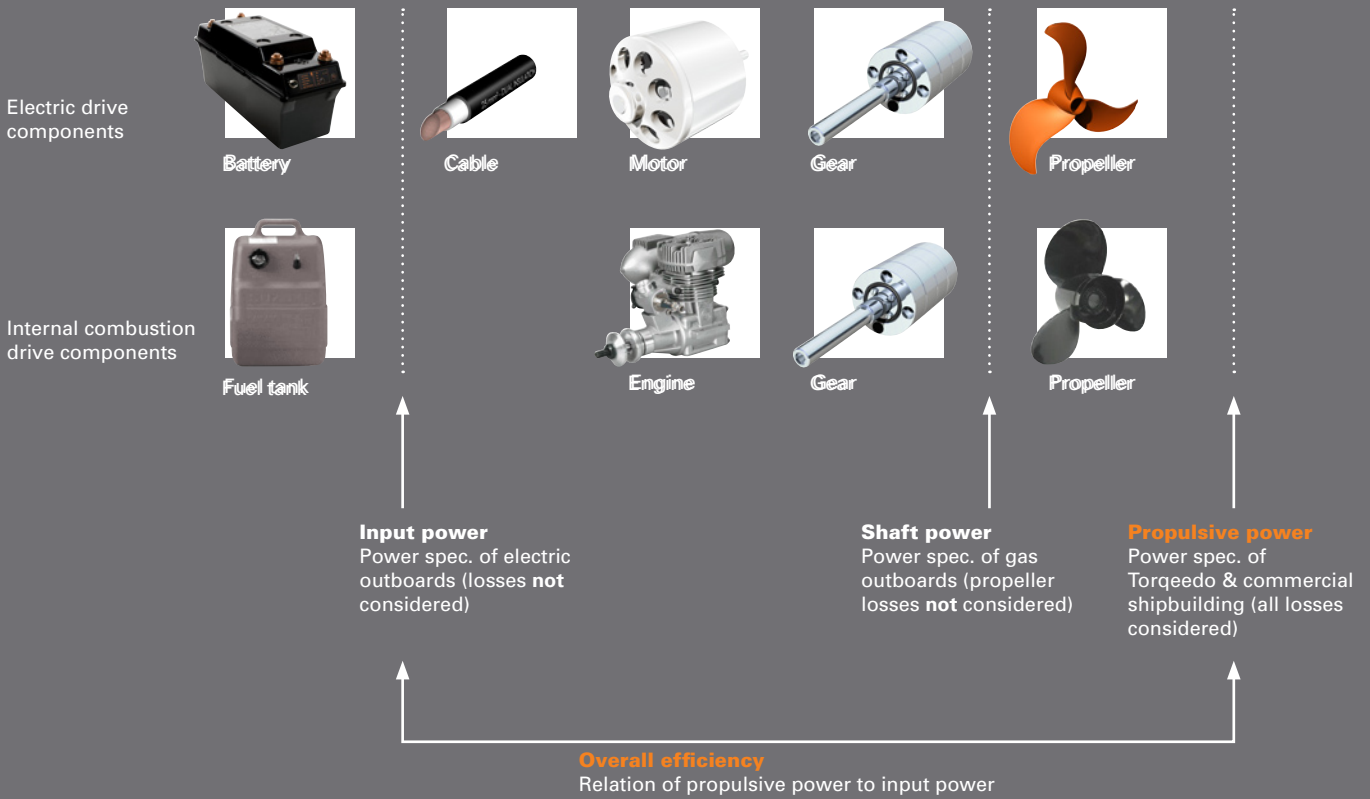

Propulsive power and overall efficiency rates of various outboards

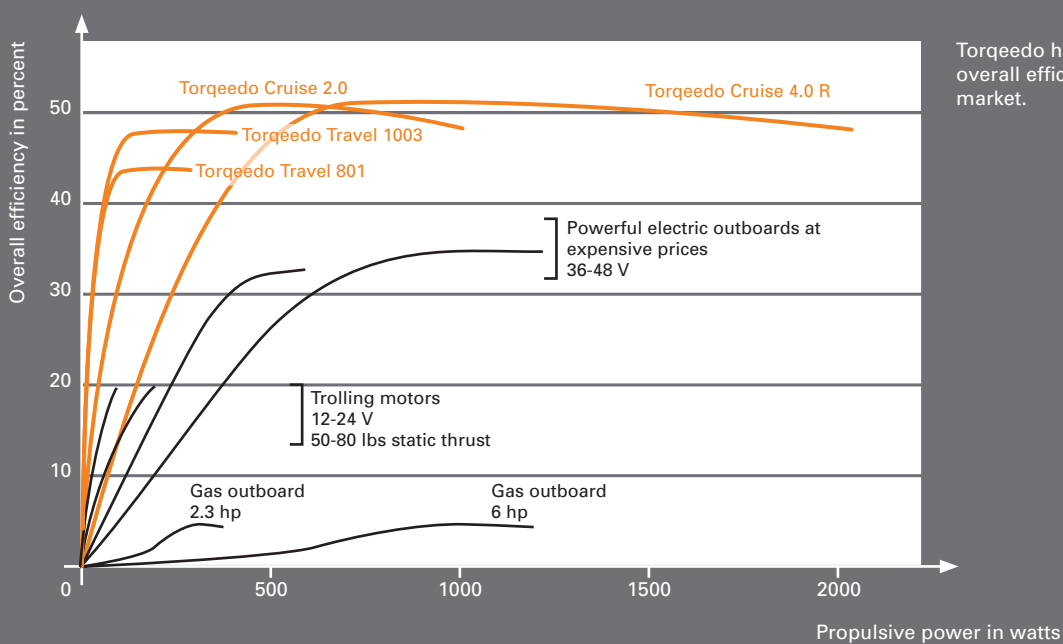

Torqueedo has by far the highest overall efficiency rates on the market.

Torqueedo Technology

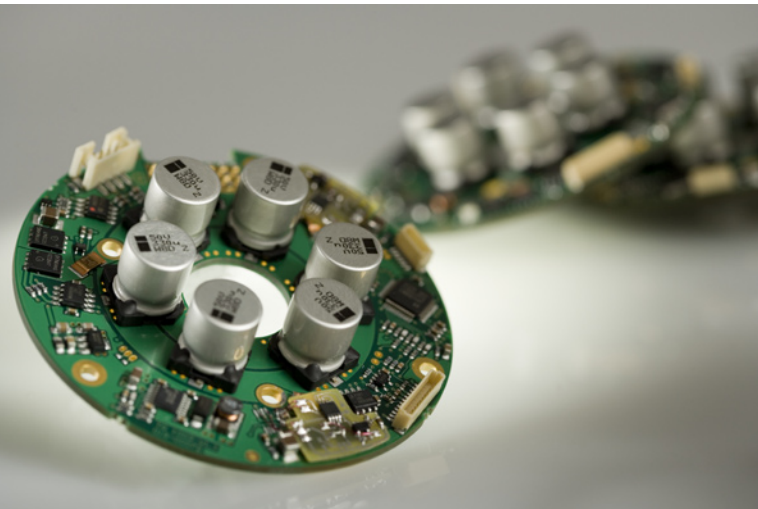

Superior technology for superior products

Torqueedo motors define new standards of efficiency and performance per weight and volume. This is the result of careful and uncompromising optimization of the individual components and their interaction combined with the very latest technology in this performance class.

Brushless electronic commutation:

In conventional motors, the alternating field necessary for driving the electric motor is provided by friction contacts commonly known as brushes. Torqueedo motors generate the alternating field contact-free via an electronic digital circuit. It is integrated in the drive system and regulates the motor 35,000 times per second. The advantages of this method are significant. The caster angle of the alternating field is better adjusted to the load and speed, making it more efficient. Additionally, there are no brush losses and the motors are maintenance-free.

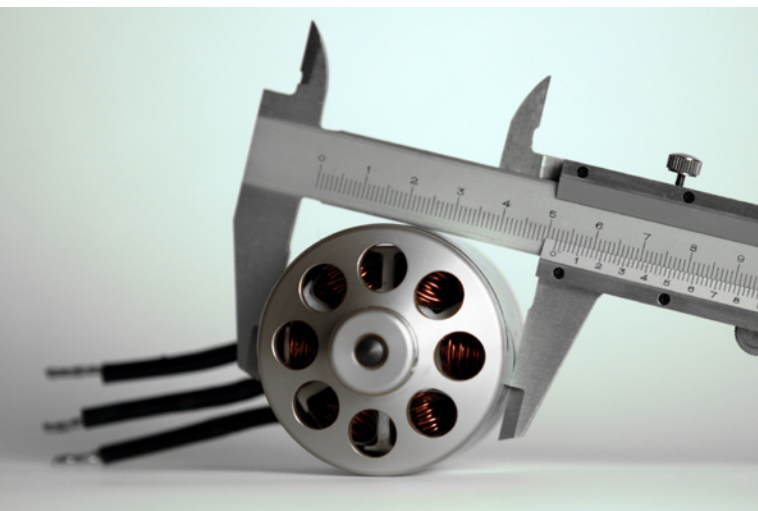

Outrunner design:

In conventional electric motors, the rotor is located inside and surrounded by the stator. The magnets are on the inside and the coils that generate the alternating field are on the outside. Consequently, the magnetic field where the torque is generated lies relatively far inside so that this design only produces a low torque. Torqueedo uses outrunners which have the coils arranged internally and the magnets are on the outside. With this design, the field where the torque is generated can be arranged further to the outside of the motor. This provides additional leverage and produces a higher torque. Additionally, the area covered by the magnets is greater on the outside, which results in even more torque.

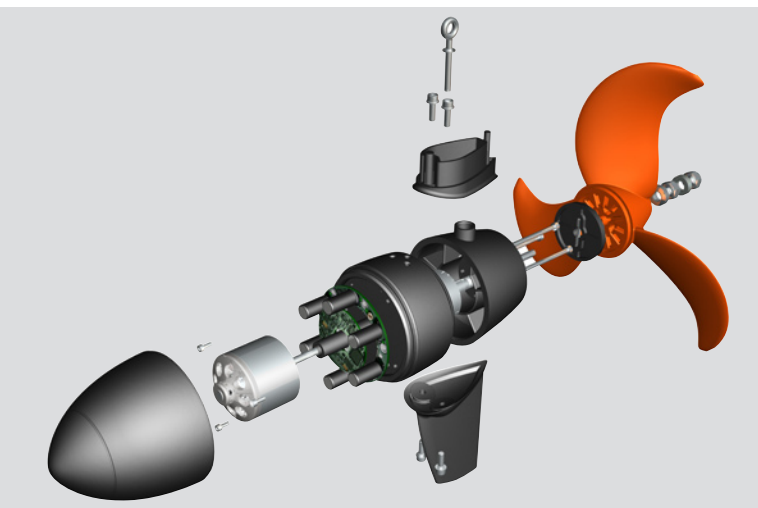

Rare-earth magnets:

Torqueedo uses rare-earth magnets instead of the usual hexaferrite magnets. They have six times the field strength, which means they deliver six times the torque.



Conventional propeller optimization:

Generally, propellers with a large diameter and high pitch, which turn slowly in water, have the highest degree of efficiency. This is because a large propeller diameter results in a high propellant flow, while a high propeller pitch has a positive effect on the additional speed induced by the propeller. In contrast, increasing rotational speed of the propeller leads to decreasing efficiencies. As a result of their exceptionally high torque, Torqeedo motors are able to drive highly efficient propellers. In other words, they can rotate large propellers with high pitches relatively slowly in the water.

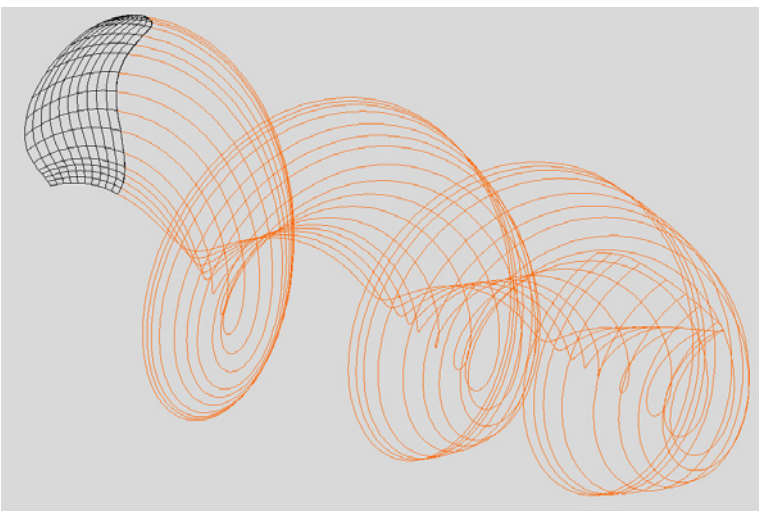

Multidimensional propeller optimization:

Most propellers used in outboard motors today are based on a series of tests carried out in the 1940's to 1960's in the Wageningen test facilities in the Netherlands and by the US Navy. The results are reflected in general design principles and applied by rule of thumb. However, for some years now, large modern ships have been fitted with propellers designed according to a multidimensional optimization calculation. Unlike standard propellers, they feature pitches and cambers that are not (almost) constant over all the propeller segments. Instead, pitch and camber are optimized on the basis of a vortex grid calculation method and a stepwise optimization over many thousand iterations for each propeller segment. With these additional design scopes, Variable-Pitch-Variable-Camber-Propellers achieve additional speed induced by the propeller at top efficiency.

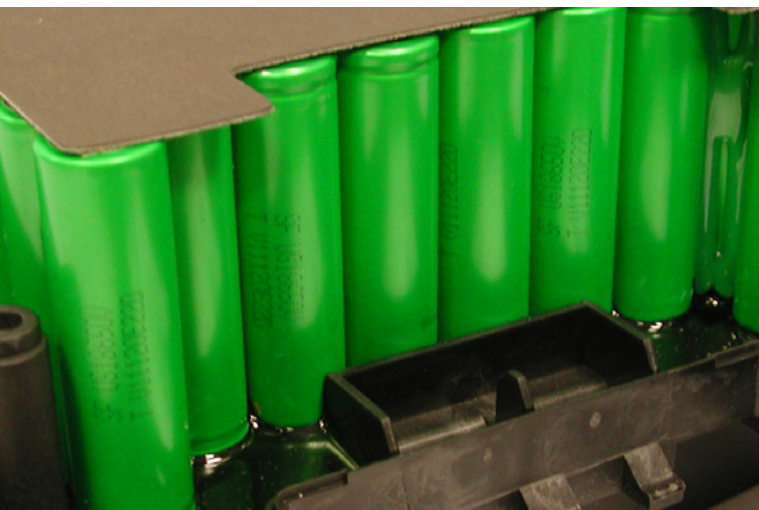

Lithium-manganese battery technology:

Lithium-based battery systems are by far the most powerful energy carriers currently available. Their special feature is their high energy density giving them the capability of storing larger quantities of energy than other batteries. In addition, lithium batteries can withstand high current, resulting in the ability to deliver their capacity even under high loads. Both of these properties are very significant for applications in boat drives. Among the various types of lithium batteries, lithium-manganese is one of the safest compounds. The lithium battery-composition and the battery packaging in safety cells are important features, as safety is almost as important for lithium batteries as it is when handling gasoline.

Torqeedo Ultralight 402

The kayak motor

The ultimate tool for kayak fishermen – or any paddler who wants to keep moving while taking a rest.

This is how we define superior technology for kayakers:

- Weight of 15 lbs, that is of course including the battery
- Motor power equivalent to 1 HP gasoline outboard
- Top speed above 6 mph, faster than any trolling motor on the market
- Range at slow speed (e.g. 2.5 mph) up to 19 miles
- Fully waterproof system



1 hp



28,8 V (integrated)



15.4 lbs



2-year limited warranty

- GPS based calculation of remaining range
- Mountable to most rigid hull kayaks

If you find anything in the world that even comes close, let us know.



1 Mounting ball attaches onto the top of the kayak. Ball-and-socket joint adapts to different kayak shapes. Only the small mounting ball is fixed permanently to the boat, the motor with all the other parts can be easily removed when not needed.

2 Extremely high-efficient drive train, performance comparable with 1 hp gas outboard.

3 Auto kick-up feature to protect from grounding.

4 Attachment point for a line to manually tilt the motor.

5 Attachment point for the “reverse drive” line (only necessary to reverse).

6 Connection to kayak steering / steering lock mechanism.

7 Lithium-manganese high-performance battery with integrated GPS-receiver.

8 Remote throttle control with magnetic on/off key and information display (for photo, see page 9, bottom).

9 The gauge on the remote throttle displays: battery charge status, remaining range at current speed, speed over ground and current power consumption in watts.

Details

Mounting: Can be mounted on most rigid-hull kayaks with stainless steel cavity dowel pins. **Steering:** Steering can be locked, after which kayak is steered with the paddle or the rudder. This results in a larger radius of turn. Alternatively, the motor can be connected to the rudder or the steering system of the boat, which makes it very maneuverable (e.g. for fishing).

Watertightness: All motor components are watertight, protected against complete immersion. **Safety:** The motor shuts off when the magnetic key on the remote throttle control is removed. Therefore, for safety reasons, the magnetic key should be attached to the wrist or the life vest. If the kayak capsizes, the motor shuts off automatically to avoid possible injury. **Battery charge time:** When fully discharged, the charge time with the charger supplied is approximately 8 hours. **Lithium-manganese battery life expectancy:** Charge cycles are not the main factor affecting the service life of the lithium-manganese battery. The battery does not have a memory-effect. Generally, a loss of capacity of 4% per year can be assumed. Ageing is accelerated if the battery is exposed to high temperatures for long periods and if it is stored fully charged for long periods. Therefore, the battery can be used in very hot conditions, but should be removed from the sun and stored in a cool place when not used. If it is stored for a longer period of time, its charge status should be about 50%. If these instructions are followed, your battery will have a life expectancy of some 6-10 years.

Integrated battery specifications: The integrated battery has a capacity of 230 Wh, i.e. 8 Ah at 28.8 V.

For technical data and ordering information, turn to pages 22/23



Remote throttle information display (9)

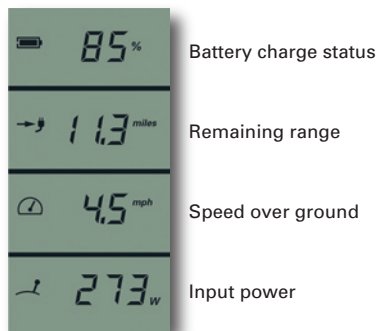

In cooperation with Hobie, we have adapted the Ultralight for the use with Hobie kayaks. The result is called Hobie eVolve: a kayak motor combining the performance of the Ultralight with plug & play installation for Hobie kayaks.

Just drop the eVolve into your Mirage well and turn your kayak into a compact electric craft. Or mount it to the Twist and Stow rudder for a quick conversion to a hybrid kayak...allowing you to pedal and use the electric motor at the same time to extend your range. Contact your Hobie dealer for details.



**Ultralight 402 with integrated battery (28.8 V / 8 Ah)
Fishing kayak (Hobie Mirage Revolution), 13.5 ft, 58 lbs**

	Speed in mph	Range in miles	Run time in hours
Slow speed	2.6	15.6	6:00
Half throttle	3.7	11.1	3:00
Full throttle	5.8	3.5	0:36

**Ultralight 402 with integrated battery (28.8 V / 8 Ah)
Touring kayak (Prijon Prilite T470), 15.4 ft, 51 lbs**

	Speed in mph	Range in miles	Run time in hours
Slow speed	2.6	18.7	7:12
Half throttle	3.9	11.7	3:00
Full throttle	6.1	4.1	0:42

Included in delivery



Lithium-battery



Remote throttle control



Battery charger

Accessories



Spare battery

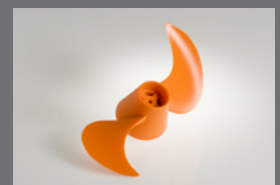

Spare propeller

Torqueedo Travel

NEW 503/1003 models

Smarter, stronger, tougher.
The perfect outboard for tenders, dinghies and daysailers has become even better.

For many of our customers, the Travel is the definitive Torqueedo outboard. While its lightness, strength and efficiency were loved by all, we were frequently asked to come up with a non-foldable, more rugged version. This is what we have done. And while we were at it, we have equipped it with more power, even higher efficiency, more battery capacity, and our onboard-computer including GPS and real-time range calculation.

If you are looking for a high-end solution for small outboards that is even cheaper than a regular gasoline outboard in the long run (taking into account service/winterization cost) your search is over.

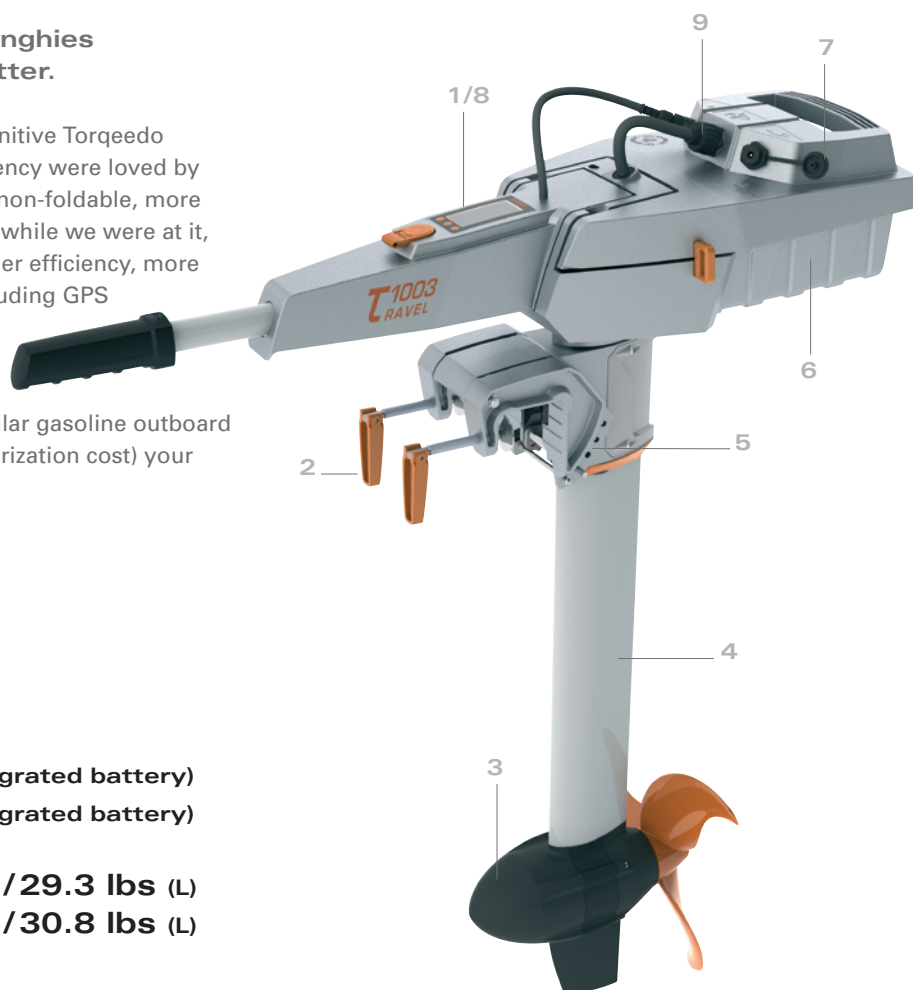

Travel 503 ____ **1.5 hp**
 Travel 1003 ____ **3.0 hp**



Travel 503 ____ **29.6 V** (integrated battery)
 Travel 1003 ____ **29.6 V** (integrated battery)



Travel 503 ____ **28.0 lbs (s) / 29.3 lbs (L)**
 Travel 1003 ____ **29.5 lbs (s) / 30.8 lbs (L)**



2-year limited warranty

- 1 Integrated GPS and information system: provides precise real-time information on battery charge status, remaining range at current speed, speed over ground and power consumption (GPS receiver located in the battery, information display located in the tiller).
- 2 Improved mechanical stability, ruggedness and suitability for salt water use.

- 3 20% higher power and approx. 10% higher efficiency, noiseless design.
- 4 Corrosion-free design, does not require a sacrificial anode
- 5 Auto-kickup feature in case of grounding
- 6 30% higher battery capacity (Travel 1003 model)

- 7 All models can be solar-charged during operation.
- 8 Audible alarm warns when battery charge status reaches 30%
- 9 Fully waterproof design, IP 67 (all components can be submersed for 1 hour at 3 ft below surface without any harm).

Details

Which Travel motor for which boat? The Travel 503 and 1003 models are both suitable for inflatables, small boats and sail boats. We recommend the Travel 401 for sail boats up to a weight of 1,500 lbs, and the Travel 1003 up to a weight of 1.5 tons. Both models consume the same level of energy at the same speed. The stronger Travel 1003 has 30% higher battery capacity and therefore superior range. Both models are available in long and short shaft versions.

Battery charge time: The battery recharge time from empty to full ranges between some 5 hours (Travel 503) and 7 hours (Travel 1003).





Lithium-manganese battery life expectancy: Charge cycles are not the main factor affecting the service life of the lithium-manganese battery. The battery does not have a memory-effect. Generally, a loss of capacity of 4% per year can be assumed. Ageing is accelerated if the battery is exposed to high temperatures for long periods and if it is stored fully charged for long periods. Therefore, the battery can be used in very hot conditions, but should be removed from the sun and stored in a cool place when not used. If it is stored for a longer period of time, its charge status should be about 50%. If these instructions are followed, your battery will have a life expectancy of some 6-10 years.

Integrated battery specifications: The battery of the Travel motors have a capacity of 300 Wh (Travel 503) and 400 Wh (Travel 1003). The batteries are rated 10 Ah @ 29.6 V (Travel 503) and 13 Ah @ 29.6 V (Travel 1003).
Charging the Travel battery from solar and from the on-board power supply: The battery can be solar charged during use. It comes with a charge connector that accepts solar chargers with a voltage between 24 V and 60 V and a charging current of 4 Amps max. To charge the battery from an on-board power supply, you will need an inverter that converts the on-board voltage to a value between 100 and 240 V (standard power outlet voltage, country-specific voltages may vary). The charger provided in the supply package connects to the inverter. High-efficiency inverters are available on the market at very affordable prices. **Watertightness:** All motor components are watertight, protected against complete immersion. **Safety:** The motor shuts off when the magnetic key on the remote throttle control is removed. Therefore, for safety reasons, the magnetic key should be attached to the wrist or the life vest.

Available March
2010



Tiller information display

 85%	Battery charge status
 113 miles	Remaining range
 4.5 mph	Speed over ground
 273 W	Input power

Travel 503 with integrated battery (29.6 V / 10 Ah)
Inflatable, dinghy, sailboat up to 1,500 lbs

	Speed in knots	Range in nm	Run time in hours
Slow speed	1.5-2.0	9.0-12.0	6:00
Half throttle	2.5-3.0	5.0-6.0	2:00
Full throttle	3.6-4.0	2.2-2.5	0:40

Travel 1003 with integrated battery (29.6 V / 13 Ah)
Inflatable, dinghy, sailboat or daysailer up to 1.5 tons

	Speed in knots	Range in nm	Run time in hours
Slow speed	1.5-2.0	12.0-16.0	8:00
Half throttle	2.5-3.0	6.5-7.8	2:40
Full throttle	4.5-5.0	2.0-2.2	0:26

Accessories



Lithium-manganese battery 300 Wh



Lithium-manganese battery 400 Wh



Spare propeller Travel 503



Spare propeller Travel 1003

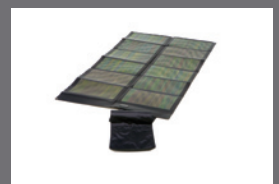

CIGS Solar Charger 62 W

Torqeedo Travel

401/801 models

Foldable, compact, light and strong. The classic Torqeedo outboard.

The Travel has won numerous accolades and innovation awards from around the globe. With its integrated lithium-manganese battery, its low weight, high power and efficiency, it is a great motor for tenders, dinghies and daysailers up to 1.5 tons. And when it comes to transport, and space-saving storage it is clearly in a class of its own.



Travel 401 ____ 1 hp
Travel 801 ____ 2 hp



Travel 401 ____ 14.8 V (integrated battery)
Travel 801 ____ 29.6 V (integrated battery)



Travel 401 ____ 25.1 lbs (s) / 26.4 lbs (L)
Travel 801 ____ 25.6 lbs (s) / 26.9 lbs (L)



2-year
limited
warranty



Details

Which Travel motor for which boat? The Travel 401 and 801 models are both suitable for inflatables, small boats and sail boats. We recommend the Travel 401 for sail boats up to a weight of 1,500 lbs, and the Travel 801 up to a weight of 1.5 tons. Both models are equipped with the same battery capacity and consume the same level of energy at the same speed. With the stronger Travel 801 you have the option to use more power and achieve higher speeds, which will empty the battery more quickly. Both models are available in long and short shaft versions. **Battery charge time:** The battery recharge time from empty to full ranges between some 5 hours (Travel 801) and 10 hours (Travel 401). **Lithium-manganese battery life expectancy:** Charge cycles are not the main factor affecting the service life of the lithium-manganese battery. The battery does not have a memory-effect. Generally, a loss of capacity of 4% per year can be assumed. Ageing is accelerated if the battery is exposed to high temperatures for long periods and if it is stored fully charged for long periods. Therefore, the battery can be used in very hot conditions, but should be removed from the sun and stored in a cool place when not used. If it is stored for a longer period of time, its charge status should be about 50%. If these instructions are followed, your battery will have a life expectancy of some 6-10 years. **Integrated battery specifications:** The battery of the Travel motors have a capacity of 300 Wh. The batteries are rated 20 Ah @ 14.8 V (Travel 401) and 10 Ah @ 29.6 V (Travel 801). **Charging the Travel battery from the on-board power supply:** To charge the battery from an on-board power supply, you will need an inverter that converts the on-board voltage to a value between 100 and 240 V (standard power outlet voltage, country-specific voltages may vary). The charger provided in the supply package connects to the inverter. High-efficiency inverters are available on the market at very affordable prices. **Downward-compatible:** The Travel can also run on lead batteries. Using the battery adapter cable set (available as an additional accessory), the motor can be connected to conventional lead-acid, gel or AGM batteries. In this case, the Travel 401 needs a battery voltage of 12 V, and the Travel 801 a battery voltage of 24 V. **For technical data and ordering information, turn to pages 22/23**



Travel 401 with integrated battery (14.8 V / 10 Ah)
Inflatable, dinghy, sailboat up to 1,500 lbs

	Speed in knots	Range in nm	Run time in hours
Slow speed	1.8-2.2	10.8-13.2	6:00
Half throttle	2.7-2.9	5.4-5.8	2:00
Full throttle	3.6-3.7	3.0-3.1	0:50

Travel 801 with integrated battery (29.6 V / 10 Ah)
Inflatable, dinghy, sailboat or daysailer up to 1.5 tons

	Speed in knots	Range in nm	Run time in hours
Slow speed	1.5-2.2	9.0-13.2	6:00
Half throttle	2.4-3.2	2.4-3.2	1:00
Full throttle	4.3-4.6	1.9-2.0	0:26

Accessories



Spare battery



Charger for spare battery



Tiller extension



Spare propeller



Battery adapter cable set

Torqeedo Cruise 2.0 with tiller control

Primary power at affordable prices

If you're looking for a powerful electric outboard motor, you have three options. You can compromise on power and purchase a cheap, less powerful trolling motor. Apart from its lower strength, it will have an overall efficiency rate of some 20% (i.e. 80% of the battery capacity is not converted into propulsive power but is lost instead).

Alternatively, you can purchase a rather expensive, very heavy motor from a small, exclusive outboard builder. These motors usually have an overall efficiency range of 30-35%.

Or you can purchase a Torqeedo. It's light, immensely powerful, and comes with an efficiency rating of more than 50%, which makes it clearly the high-end solution on the market period. In addition, due to our industrial approach to electric outboards, it is also affordably priced.

The Cruise 2.0 is a 24-volt motor that has the propulsive power of a 5 hp gas outboard and the thrust of a 6 hp gas outboard. The 2010 models feature a new improved driveline with improved longevity, higher efficiency and less noise.



5-6 hp



24 V



40.8 lbs (s) / 41.9 lbs (L)



2-year
limited
warranty



1 Angle-adjustable telescopic tiller for stepless forward/reverse drive.

2 Voltage indicator, provides information to estimate current charge status of connected batteries.

3 Transom bracket with gas-spring-supported tilt/trim mechanism.

4 Hydrodynamically optimized shaft.

5 High-efficiency drive train converts battery energy into propulsive power with unparalleled efficiency.

6 American Wire Gauge 3 cable set for connection of Cruise 2.0 with 24V battery bank, including high-current plugs for easy installation, as well as main switch and fuse as suggested by international technical safety guidelines. (for photo, see page 15, bottom).



Test winner
10 / 2006
Outboards > 1 kW

Details

Battery supply: The Cruise 2.0 requires a battery voltage of 24 V. We recommend a battery supply of two batteries, each with a capacity of at least 180 Ah. Lead-based batteries are not resistant to high current, i.e. the capacities indicated on the casing are not available when the batteries are to be fully discharged in a short time (e.g. 1 or 2 hours). For this reason, you should allow for sufficient reserves. Alternatively, the Cruise 2.0 can also be run with at least one lithium-manganese battery from the Torqeedo Power series. **Connection to remote throttle/steering:** No longer available with this model. For this application, we developed our new models, Cruise 2.0 R and 4.0 R. See details on pages 16/17. **Saltwater use:** The Cruise R models shown on pages 16/17 are better suited for the use in salt water than this tiller version. They are also waterproof IP 67. Using the Cruise 2.0 tiller version in saltwater does require protection of the contacts and protection from complete submersion. **For technical data and ordering information, turn to pages 22/23**

The power of an electric drive system is typically limited by the available battery supply: Electric motors are superior to internal combustion engines in all aspects and in every power class (they are typically smaller, lighter, easier produce, easier to maintain etc.). However, batteries have a much lower energy density than gas. Therefore, especially when installing powerful electric outboards, paying attention to the overall efficiency of the outboard is imperative – because it deter-

mines how much range and power you receive from a given battery supply, which is typically limited by weight and volume constraints. Currently no outboard motor comes even close to a Torqueedo in this respect.



Cruise 2.0 (with 2 x 12 V / 200 Ah lead batteries)
Rowing boat, 20 ft, 1,650 lbs

	Speed in knots	Range in nm	Run time in hours
Slow speed	1.5	165.0	110:00
Half throttle	2.6	42.9	16:30
Full throttle	5.5	11.0	2:00

Cruise 2.0 (with 2 x 12 V / 200 Ah lead batteries)
30 square-metre skerry cruiser, 40 ft, 2.6 tons

	Speed in knots	Range in nm	Run time in hours
Slow speed	1.5	165.0	110:00
Half throttle	2.6	42.9	16:30
Full throttle	4.9	9.8	2:00

Included in delivery

Accessories



Cable set (6)



Tiller extension



Spare propeller



Cable set extension



Torqueedo Power

Torqeedo Cruise 2.0 R/4.0 R

The standard for powerful electric outboards

The Cruise R models come with a whole set of superlatives:

As all Torqeedo outboards, they are by far the highest efficiency outboards in their power class. This feature is especially important for strong outboards, if you want to avoid carrying excessive amounts of batteries. With an overall efficiency of 51% they transform over half of the energy supplied by the batteries into propulsive power (measured after all losses, including propeller losses). As far as we know, this value is substantially higher compared to any other manufacturer on the market.

The models are waterproof (IP 67), protected against submersion for at least 1 hour. They are equipped with our onboard computer and GPS, calculating the remaining range based on power consumption, speed and reading the attached external batteries.

They offer by far the best power-to-weight ratio among all electric outboards.

And they certainly offer the best price-performance ratio of the industry in this power class.



Cruise 2.0 R ___ 5-6 hp
Cruise 4.0 R ___ 8-9.9 hp



Cruise 2.0 R ___ 24 V
Cruise 4.0 R ___ 48 V



Cruise 2.0 R ___ 37.5 lbs (S) / 38.6 lbs (L)
Cruise 4.0 R ___ 39.7 lbs (S) / 40.8 lbs (L)



2-year
limited
warranty

Remote throttle information display (8)



Battery charge status

Remaining range

Speed over ground

Input power



- 1 Connection for standard remote steering control.
- 2 Integrated GPS receiver supplies data to on-board information system.
- 3 Handle for tilting and trimming the motor.
- 4 Thread for locking the motor steering in a defined position (e.g. for sailing boats that steer with the rudder).
- 5 High-efficiency drive train converts battery energy into propulsive power with unparalleled efficiency.

- 6 Transom bracket with tilt/trim mechanism.
- 7 Tilt/lock mechanism. Setting "Tilt/Auto kick-up" enables tilting and activates grounding protection (full-throttle reverse drive not possible). "Lock" setting enables full-throttle reverse drive (grounding protection disabled, tilting not possible).
- 8 The gauge on the remote throttle displays: battery charge status, remaining range at current speed, speed over

ground and current power consumption in watts.

Included in delivery

American Wire Gauge 3 cable set for connection of Cruise R models with battery bank, including high-current plugs for easy installation, as well as main switch and fuse as suggested by international technical safety guidelines. Remote throttle control with magnetic on/off pin and information display. Link arm and guide tube.

Details

Battery supply: The Cruise 2.0 R requires a battery voltage of 24 V, the Cruise 4.0 R requires 48 V. We recommend a battery supply of batteries with at least 180 Ah capacity each. Lead-based batteries are not resistant to high current, i.e. the capacities indicated on the casing are not available when the batteries are to be fully discharged in a short time (e.g. 1 or 2 hours). For this reason, you should allow for sufficient reserves. Alternatively, the Cruise 2.0 R can also be run with at least one lithium-manganese battery from the Torqeedo Power series. The Cruise 4.0 R can be run with two batteries from the Torqeedo Power series. **Connection to remote throttle/steering:** The motor is designed for connection with a standard remote steering system (e.g. Teleflex). Included in the delivery are a guide tube which runs through the transom bracket as well as a link arm. Also, included is a remote throttle control with integrated on-board information display. **Tiller control:** No longer available for this model. See details on our tiller version of the Cruise 2.0 above. **On-board information system:** The computer integrated in the remote throttle control analyses and combines information received from the motor, batteries and GPS. While the motor and GPS data are very accurate, the battery information is based on estimates which can vary according to the connected battery type, age and capacity in each case. The indications of battery charge status and remaining range are therefore estimates that are less accurate than those of the Ultralight and Travel models. **Licence friendly:** The Cruise 4.0 R has a shaft performance of 3.5 kW or 4.7 hp. This puts it under the regulation threshold for many inland lakes (e.g. 5 hp). Yet, due to the super efficient propeller it has the propulsive power of an 8 hp gas outboard (relating to boats in displacement drive). Its static thrust is as strong as a 9.9 hp internal combustion engine (See pages 4/5 for details on performance indicators). **For technical data and ordering information, turn to pages 22/23**

The Cruise 4.0 R pushes a well-stocked 24 ft pontoon boat with 25" pontoons and seven people aboard at more than 6 mph. Cruise 4.0 twin installations can run pontoon boats at up to 12 mph.



On light boats, Cruise 4.0 R models with lithium-batteries and high-speed propellers run at 11-15 mph. Twin installations of Cruise 4.0 R motors can put boats into plane also with lead-gel or AGM batteries.



Cruise 2.0 R (with 2 x 12 V / 200 Ah lead batteries)
30 square-metre skerry cruiser, 40 ft, 2.6 tons

	Speed in knots	Range in nm	Run time in hours
Slow speed	1.5	165.0	110:00
Half throttle	2.7	44.6	16:30
Full throttle	5.0	10.0	2:00

Cruise 4.0 R (with 4 x 12 V / 200 Ah lead batteries)
Pontoon boat, 24 ft, well stocked

	Speed in mph	Range in miles	Run time in hours
Slow speed	4.1	41.0	10:00
Half throttle	5.3	21.2	4:00
Full throttle	6.1	12.2	2:00

Accessories



High-speed propeller



Spare propeller



Torqueedo Power



Charger

Torqeedo Power 26-77

More power, lighter weight – Torqeedo lithium-manganese batteries for the highest demands

Lithium batteries represent the leading battery technology on the market today. The advantages they offer over conventional batteries are dramatic: They have a much higher energy density, they easily deliver high current and they also feature outstanding cyclic stability and therefore a long service life. Lithium batteries provide various options for use on boats. On the one hand, you can save around 70% battery weight. Alternatively you can increase the capacity of your battery bank substantially and drive more powerful electric outboards or simply have more energy at your disposal on the ship. While batteries from the Torqeedo Power series reflect latest battery technology, they've also been proven on the market for several years.



— 2.0 kWh (25.9 V, 77 Ah)



— 41.9 lbs



2-year
limited
warranty



1 Solid copper connections with M19 threads for optimum electric conduction.

2 Two plus and two minus poles for conveniently connecting several batteries. For larger battery banks, provision is made for connecting batteries with industrial-standard copper rails.

3 RS485 bus interface for reading battery information for battery bank monitor. Data transferred includes e.g. capacity, charge status, voltage and internal temperature.

4 Control panel with indicator of charge status.

Details

Capacity: 2 kWh **Charge:** 77 Ah **Rated voltage:** 25.9 V **Final voltage:** 29.05 V **Final discharge voltage:** 21.0 V **Electrochemical type:** Lithium-manganese **Cells:** 18650 safety cells, quantity 336 **Fuses:** The battery cells in Torqeedo Power batteries can produce very high currents. For safety reasons, they are equipped with standard 120 A internal fuses. The maximum power delivery per battery is approximately 3.1 kW. Higher power deliveries require either more batteries in series or Torqeedo must modify the fuses (then up to 10 kW can be delivered per battery). **Connecting batteries (parallel and serial):** Up to 40 batteries per bank. Installation of banks consisting of 2 batteries or more only after instruction by Torqeedo. Serial connections of more than 2 batteries may be performed only by personnel trained and authorized explicitly by Torqeedo. **Operating temperature:** -20° C to +65° C **Charging temperature:** 0° C to +45° C **Weight:** 42 lbs **Dimensions in inches:** 20 x 7 x 9. **For ordering information, turn to page 23**

Safety is a the primary design principle for Torqeedo lithium-batteries. Three aspects are important:

Chemical battery composition: Batteries are frequently described non-specifically as lithium-ion batteries. This is a collective term that groups together various types of battery chemistries. Some of these, e.g. lithium-cobalt or lithium-cobalt mixed with nickel, fail in appropriate safety tests and are fire and explosion hazards. This is why they should not be used in larger batteries. Other battery compositions such as lithium-iron-phosphate or the lithium-manganese type used by Torqeedo are intrinsically safe, even in a case when the safety electronics fail, or if the batteries are mechanically damaged.

Battery casing: If there is an internal short-circuit, explosive gases can develop inside a lithium battery. For lithium batteries in polymer packaging, this can result in pressure

being build up, which can ultimately burst the casing. The explosive gas then released is a serious hazard. For this reason, Torqeedo does not employ polymer packaging but metal safety cells, which feature a safety vent. If internal pressure builds up, the metal cylinder expands at a pre-defined point and mechanically separates the cathode from the anode. This deactivates the battery, explosive gas will not be released.

Fuses: Unlike lead batteries, lithium batteries can deliver very high currents without problems. In case of a short-circuit, this is an undesirable side effect. Therefore, Torqeedo batteries have internal 120 A fuses so that any incorrect installation without external fuses will not cause severe unwanted side effects.

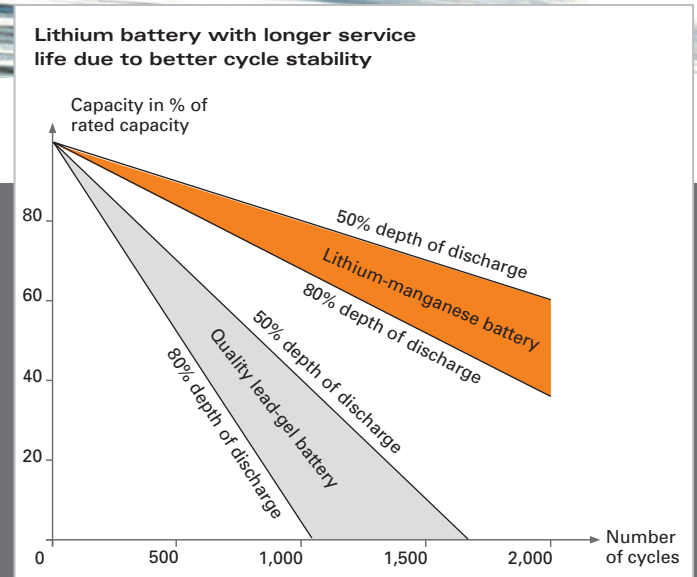
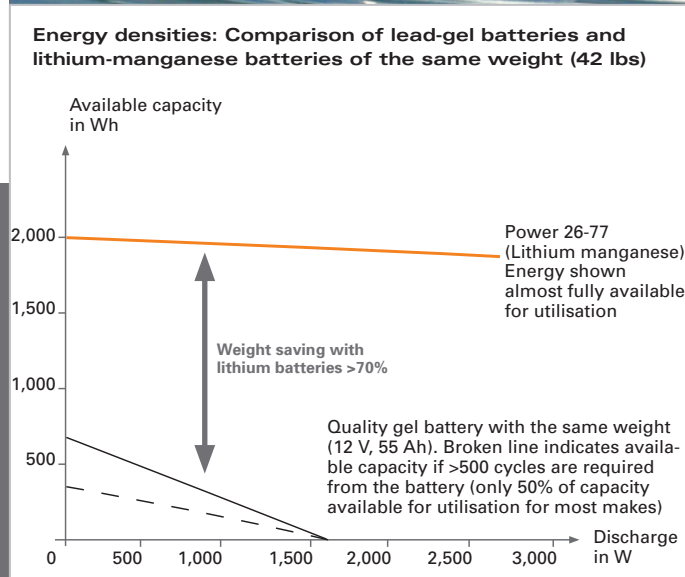

Accessories



Charger



Battery bank monitor

CIGS Solar Charger 62 W

Independence made simple

For many years running your boat from solar energy was a cumbersome task. It generally involved large solar panels, which had to be permanently installed. These times are over. New CIGS solar cells (Copper Indium Gallium Diselenide) offer up to twice the efficiency compared to conventional thin film solar cells. Combined with the low energy consumption of the highly efficient Torqeedo outboards, running your boat from solar power has become very simple.

From a surface area of less than 11 square feet, the CIGS solar charger provides sufficient energy to charge the lithium-batteries of the Travel 503/1003 series quicker than the chargers that come with the products. What a convenient and clean way to charge the batteries of your tender, sailboat or fishing boat. If you use the CIGS solar charger while running your boat, you can run between 1.3 and 2.2 knots from the energy provided by the charger (results vary depending on the boat). Yet, if you do not need the CIGS Solar Charger, it folds into a handy format of 37 x 32 cm and can be transported and stored easily. It weighs a mere 1.6 kg and connects with the Travel 503/1003 models as well as other 24 V devices.

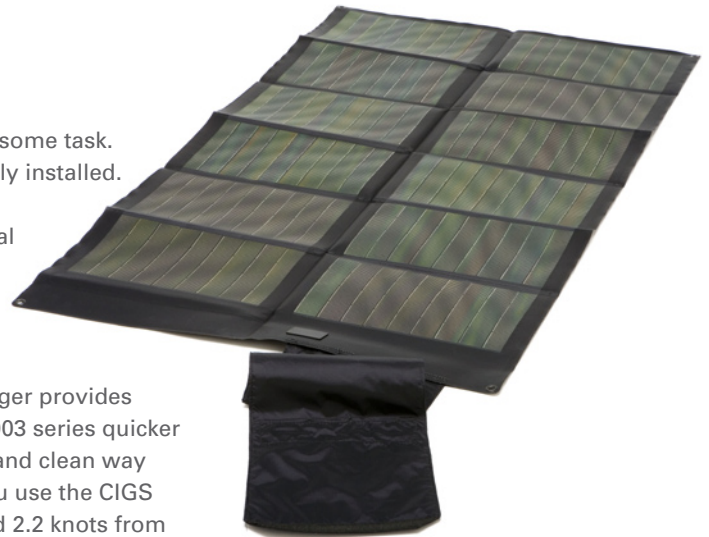

Needs to be stored dry



Travel 503/1003 models



Unfolded_52.5 x 30.0 x 0.1 inches

Folded_14.5 x 8.5 x 1.5 inches



55 oz.



2-year limited warranty



Details

Output power: Maximum 62 watts; under typical sun exposure in North America and Europe output powers of 40-45 watts can be expected. **Cell type:** CIGS (Copper Indium Gallium Diselenide) **Efficiency:** Cell efficiency 9.8%, module efficiency 7.5% **Voltage:** open circuit voltage 56 V, designed to charge 24 V systems. **Charging options:** The batteries of the Travel 503/1003 models can be solar charged while not in use, as well as during operation. **Charging time from 0% to 100% charge:** The 300 Wh battery of the Travel 503/1003 series will charge in approx. 8 hours; the 400 Wh battery of the Travel 503/1003 series will charge in approx. 10 hours of sunlight. **Compatibility/plugs:** works with other 24 V electric devices; comes with extension cable and 2.5 mm ID barrel plug; will fit onto Travel 503/1003 models. **Weatherproofness:** The CIGS solar cells are laminated onto a Rip-Stop Nylon. They are weatherproof and meet military specifications (Mil Std 810). After use, they need to be stored in a dry condition. **Light-soaking:** If not used for a longer period of time, CIGS cells may require some 3-4 hours of light-exposure to reach their full output power again. **Power guarantee:** Limited warranty of 2 years refers to 80% of specified power.

If you do not want to go for lithium-batteries, we recommend you go for Optima

For economical reasons, many of our customers use Torqeedo outboards of the Cruise series together with lead-based battery systems (lead-acid, lead-gel, AGM). As we want our customers to enjoy clean, quiet and powerful electric boating with the range they desire, we have conducted a series of tests to determine, which batteries are best suited for a marine propulsion application. Based on our tests, we can recommend Optima BlueTop batteries of the DC series:



Higher effectively available capacity:

The nominal battery capacity of any lead-based battery is rated based on a slow rate of discharge, typically over 20 hours. If the battery is emptied within 2 or 3 hours only a fraction of this nominal capacity is effectively available to the user. For Optima batteries, this effect is significantly lower than for all other batteries tested. Therefore, among various makes of batteries with the same capacity rating (in Ah) the Optima battery will have the highest effectively available capacity.

Best deep discharge characteristics:

If you deep-discharge a battery completely, many batteries will only work for a few cycles before losing a substantial share of their capacity. Optima batteries will keep around 70% of their original capacity even after 300 cycles at 90% depth of discharge. This is as impressive as it is important: In an electric propulsion application, deep discharges occur fairly frequently.

Smaller and lighter battery supply:

Due to the factors mentioned above, boaters can run their electric outboard from a smaller and lighter battery bank if they use Optima batteries, while achieving the same speed and range a somewhat larger and heavier different battery bank would have offered.

Economical solution:

While Optima batteries require a higher initial purchase price than many other makes, they are among the most economical solutions on the market, taking into account the effectively available capacity and the longer lifetime.

Battery performance in marine propulsion applications

- Optima batteries with more effective capacity at comparable Ah-ratings
- Lower weight and volume of battery bank
- Very economical in the long run due to better longevity

Battery	Technology	Nominal capacity in Ah	Nominal capacity of battery bank consisting of 8 batteries in kWh*	Effectively available battery bank capacity @ 4,000 W consumption and if battery bank shall last for 300 cycles (in kWh)**	Run-time @ 4,000 watts in hrs	Run-time @ 1,000 watts in hrs	Weight of battery banks in lbs
Battery A	AGM	95	9.120	2.702	0:41	3:04	568
Battery B	AGM	90	8.640	2.864	0:43	3:19	541
Battery C	AGM	90	8.640	4.048	1:01	4:35	504
Battery D	AGM	90	8.640	4.701	1:11	5:23	487
Battery E	Gel	80	7.680	3.340	0:50	4:00	497
Battery F	Gel	80	7.680	3.293	0:49	3:59	400
OPTIMA DC	AGM	75	7.200	5.422	1:22	6:13	467

* Capacity of batteries in Wh is calculated as Voltage (V) times Charge (Ah). The capacity of the battery bank is calculated as capacity per battery (in Wh) times number of batteries.

** Taking into account different high current capabilities and different deep charge characteristics of the various batteries. The deep discharge characteristics are considered under the prerequisite that 300 cycles must only lead to 30% loss of the original capacity. Under this prerequisite, Optima batteries can be discharged 90% for 300 times. Other batteries can only be discharged 65%, 50% or even only 35% (starter batteries) for 300 times while keeping 70% of their original capacity.

Technical data and ordering information

Technical data	Ultralight 402	Travel 401 S/L	Travel 801 S/L	Travel 503 S/L	Travel1003 S/L	Cruise 2.0 S/L	Cruise 2.0 RS/RL	Cruise 4.0 RS/RL
Input power in watts	400	400	800	500	1,000	2,000	2,000	4,000
Propulsive power in watts	180	175	350	220	480	900	1,020	2,040
Comparable gas outboards (propulsive power)	1 hp	1 hp	2 hp	1.5 hp	3 hp	5 hp	5 hp	8 hp
Comparable gas outboards (thrust)	2 hp	2 hp	4 hp	2 hp	4 hp	6 hp	6 hp	9.9 hp
Maximum overall efficiency in%	45	44	44	44	48	45	51	51
Static thrust in lbs*	33	40	68	40	68	121	110	214
Integrated battery	230 Wh LIMA	300 Wh LIMA	300 Wh LIMA	300 Wh LIMA	400 Wh LIMA	no	no	no
Rated voltage in volts	28.8	14.8	29.6	29.6	29.6	24	24	48
Final voltage in volts	33.2	16.8	33.6	33.6	33.6	-	-	-
Total weight in lbs	15.4	25.1 (S) / 26.4 (L)	25.6 (S) / 26.9 (L)	28.0 (S) / 29.3 (L)	29.5 (S) / 30.8 (L)	40.8 (S) / 41.9 (L)	37.5 (S) / 38.6 (L)	39.7 (S) / 40.8 (L)
Weight of motor without battery in lbs	9.9	17.4 (S) / 18.7 (L)	17.9 (S) / 19.2 (L)	19.6 (S) / 20.9 (L)	19.6 (S) / 20.9 (L)	-	-	-
Weight of integrated battery in lbs	5.5	7.7	7.7	8.4	9.9	-	-	-
Shaft length in inches	17.7	23 (S) / 28 (L)	23 (S) / 28 (L)	23 (S) / 28 (L)	23 (S) / 28 (L)	24.6 (S) / 29.3 (L)	24.6 (S) / 29.3 (L)	24.6 (S) / 29.3 (L)
Propeller dimensions in inches	8 x 8	12 x 10	12 x 10	12 x 10	11.5 x 8.1	12 x 10	12 x 10	12 x 10
Propeller speed in rpm	1,200	700	700	700	1,200	1,300	1,300	1,300
Control	Remote throttle control	Tiller control	Tiller control	Tiller control	Tiller control	Tiller control	Remote throttle control	Remote throttle control
Steering	Provision for connection to kayak rudder: lockable	180° lockable	180° lockable	360° lockable	360° lockable	360° lockable	Provision for connection to standard remote steering, lockable	Provision for connection to standard remote steering, lockable
Tilting device	Manual with grounding protection	Manual	Manual	Manual with grounding protection	Manual with grounding protection	Gas pressure spring assisted	Manual with grounding protection	Manual with grounding protection
Trim device	-	Manual, 3-step	Manual, 3-step	Manual, 4-step	Manual, 4-step	Manual, 5-step	Manual, 4-step	Manual, 4-step
Stepless forward/reverse drive	Yes	Yes	Yes	Yes	Yes	Yes	Yes	Yes



* Torqeedo static thrust measurement is based on globally valid ISO standards. Static thrust figures for conventional trolling motors are measured digressively, which results in higher values. In order to compare Torqeedo static thrusts data with conventional trolling motors, add approximately 50% to the Torqeedo static thrust values.

Ordering information

	Item No.	Product	Description	MSRP in US\$
Ultralight	1401-00	Ultralight 402	Kayak motor, 1 HP equivalent with integrated LIMA high-performance battery, charger, remote throttle control, GPS-based range calculator, information display, magnetic on/off pin and travel bag	1,799.00
	1411-00	Spare battery Ultralight 402	LIMA high-performance battery with integrated GPS receiver, 230 Wh, 28.8 V, 8 Ah	599.00
	1412-00	Charger for spare battery Ultralight 402	40 watt charger (20 V, 2 A) for charging Ultralight 402 batteries, for power connection with 100-240 V and 50-60 Hz	69.99
Travel	1120-00	Travel 503 S	High-efficiency outboard with integrated 300 Wh LIMA high-performance battery, 1.5 HP equivalent, with GPS-based range calculation, information display, charger included, short shaft version	1,599.00
	1121-00	Travel 503 L	As item 1120-00, but with long shaft	1,599.00
	1122-00	Travel 1003 S	High-efficiency outboard with integrated 400 Wh LIMA high-performance battery, 3 HP equivalent, with GPS-based range calculation, information display, charger included, short shaft version	1,899.00
	1123-00	Travel 1003 L	As item 1122-00, but with long shaft	1,899.00
	1124-00	Spare battery 300 Wh for Travel 503/1003 models	LIMA high-performance battery with integrated GPS receiver, 300 Wh, 29.6 V, 10 Ah	599.00
	1125-00	Spare battery 400 Wh for Travel 503/1003 models	LIMA high-performance battery with integrated GPS receiver, 400 Wh, 29.6 V, 14 Ah	699.00
	1127-00	Charger for spare battery Travel 503/1003 models	40 watt charger (12 V, 3.3 A) for charging 300 Wh and 400 Wh batteries, for power connection to 100-240 V and 50-60 Hz	69.99
	1107-00	Travel 401 S	Foldable outboard, 1 HP equivalent, with integrated LIMA high-performance battery, charger and travel bag, short shaft version	1,499.00
	1108-00	Travel 401 L	As item 1107-00, but with long shaft	1,499.00
	1109-00	Travel 801 S	Foldable outboard, 2 HP equivalent, with integrated LIMA high-performance battery, charger and travel bag, short shaft version	1,699.00
	1110-00	Travel 801 L	As item 1109-00, but with long shaft	1,699.00
	1111-00	Spare battery Travel 401	LIMA high-performance battery with integrated charge status display, 300 Wh, 14.8 V, 20 Ah	599.00
	1112-00	Spare battery Travel 801	LIMA high-performance battery with integrated charge status display, 300 Wh, 29.6 V, 10 Ah	599.00
	1113-00	Charger for spare battery Travel 401	40 watt charger (20 V, 2 A) for charging Travel 401 batteries, for power connection to 100-240 V and 50-60 Hz	69.99
	1114-00	Charger for spare battery Travel 801	80 watt charger (40 V, 2 A) for charging Travel 801 batteries, for power connection to 100-240 V and 50-60 Hz	69.99
1115-00	Battery adapter cable set	Adapter for connection of Travel 401/801 models to standard lead-, gel- or AGM-batteries with 12 V (Travel 401) or 24 V (Travel 801), incl. 10 ft connection cable with fuse and short connection cable for linking 2 batteries	199.00	
Cruise	1205-00	Cruise 2.0 S	High-efficiency and extremely powerful 24 V motor, thrust comparable to 6 hp gas outboard, incl. 10 ft cable set, AWG 3, with fuse and main switch, tiller operated, short shaft version	2,699.00
	1206-00	Cruise 2.0 L	As item 1205-00, but with long shaft	2,749.00
	1209-00	Cruise 2.0 RS	High-efficiency and extremely powerful 24 V motor, thrust comparable to 6 hp gas outboard, incl. remote throttle control, magnetic on/off key, GPS-based range calculation, information display, 10 ft cable set AWG 3, with fuse, main switch and link arm to connect to standard steering system	3,199.00
	1210-00	Cruise 2.0 RL	As item 1209-00, but with long shaft	3,249.00
	1211-00	Cruise 4.0 RS	High-efficiency and extremely powerful 48 V motor, thrust comparable to 9.9 hp gas outboard, incl. remote throttle control, magnetic on/off key, GPS-based range calculation, information display, 10 ft cable set AWG 3, with fuse, main switch and link arm to connect to standard steering system	3,699.00
	1212-00	Cruise 4.0 RL	As item 1211-00, but with long shaft	3,749.00
	1204-00	Cable set extension Cruise models	Extension for Cruise cable set, 6 ft long, with high-current plugs	99.00
Propeller / accessoires	1129-00	CIGS Solar Charger 62 W	High-efficiency foldable and flexible CIGS solar module, plugs simply into the integrated LIMA batteries of Travel models 503/1003 and charges also other 24 V devices	999.00
	1901-00	Spare prop. Travel 401, 801, BaseTravel, Cruise tiller with serial number <5,000	12" x 10" variable-pitch-variable-camber (VPVC) propeller developed especially for the torque characteristic and performance range of Torqeedo-motors. Made of impact-resistant glass-fibre reinforced PBT (polybutylene terephthalate), complete with nuts, disc springs and shear pin	79.99
	1912-00	Spare propeller Ultralight 402	As item 1901-00, but with 8" x 8"	79.99
	1915-00	Spare prop. Cruise R, Cruise tiller with serial nr. >5,000	As item 1901-00	79.99
	1916-00	Highspeed prop. Cruise R, Cruise tiller serial nr. >5,000	As item 1901-00, but with 12" x 12"	499.00
	1917-00	Spare propeller Travel 1003	As item 1901-00, but with 11.5" x 8.1"	79.99
	1906-00	Tiller extension	Longer tiller handle, 24 inches long, suitable for use on Travel 401/801 models, BaseTravel and Cruise tiller models	39.99
Power	2101-00	Torqeedo Power 26-77	LIMA high-performance battery, capacity 1,994 Wh, rated voltage 25.9 V, charge 77 Ah, weight 42 lbs, connection to other batteries only after consultation with Torqeedo	N/A
	2205-00	Charger 350 W for Torqeedo Power 26-77	Charger with lithium charging characteristics (CC-CV charging), charge power 350 W, i.e. Torqeedo Power 26-77 fully charged in less than 6 hours.	N/A
	2302-00	Cruise-Power adapter	Adapter to connect Cruise model cable sets with Torqeedo Power 26-77	N/A



Europe and international

Torqeedo GmbH
Petersbrunner Str. 3a
82319 Starnberg
Germany
T +49-8151-268 67-0
F +49-8151-268 67-19

North America

Torqeedo Inc.
171 Erick Street, Unit A-1
Crystal Lake, IL 60014
USA
T +1-815-444-88 06
F +1-815-444-88 07

www.torqeedo.com

This catalog is printed on chlorine-free paper sourced from sustainable forestry. Goods are delivered exclusively according to our Terms of Sale and Delivery according to the currently valid General Business Conditions of Torqeedo.

We reserve the right to make formal changes and changes to the price of our products.

Your Torqeedo retailer