

50Hz Models  
Now Available!

# Dometic EnviroCool Kit

## Climate Control at the Touch of a Button

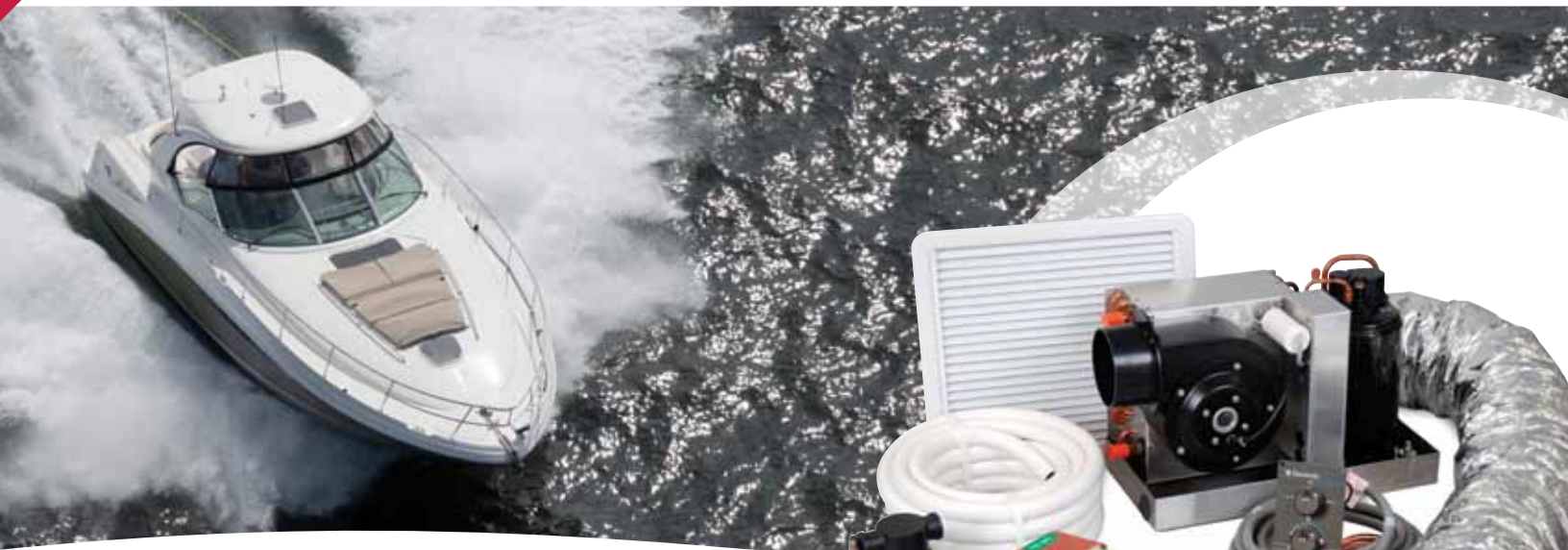

Dometic EnviroCool  
5,000 BTU/hr Kit

**Enjoy ideal temperatures in your boating environment with Dometic's EnviroCool Series of marine air conditioning kits.** The EnviroCool Series offers a wide range of BTU capacities from 3,500 to 15,000 BTU/hr to allow you to size your system for ultimate cooling. The EnviroCool series uses environmentally safe R-134A (3.5K BTU/hr. model) and R-417A (5K - 15K BTU/hr. models) refrigerants.

The EnviroCool kit includes everything needed for a professional installation on boats with or without an air conditioning system.

EnviroCool units use high-velocity blowers that eliminate blower-motor overhang for a smaller installation footprint. For flexibility in connecting to ductwork, the blower is rotatable to either a horizontal or vertical position. The compact, space-saving design is contained in a stainless-steel drain pan, and the pre-installed return-air filter is easily removable and cleanable.

For system operation, EnviroCool uses a two-knob mechanical switch for reliable control over air conditioner functions.

### Key Benefits

- Small, compact space-saving design.
- Stainless-steel drain pan.
- Available in 50Hz and 60Hz models.
- Green gas (R-134A and R-417A).
- Two-knob mechanical control.
- Complete air conditioning kit - All pieces, parts, and pump.
- High velocity, rotatable blower - either horizontal or vertical positions.
- Pre-installed return-air filter, easily removable and cleanable.
- Optional dual-duct kit for 6.5K BTU/hr and up models (details on reverse side).
- Available capacities (in BTU/hr): 3,500, 5,000, 6,500, 9,000, 11,000, and 15,000.
- Replaces Cool Mate and Zephyr.

# Technical Specifications for Dometic EnviroCool Air Conditioners

Model	ECM03.5	ECM05		ECM06.5	ECM09	ECM11		ECM15	
Capacity (BTU/hr)	3,500	5,000		6,500	9,000	11,000		15,000	
Power (Volt/Hz/Ph)	115/60/1	115/60/1	220/50/1	115/60/1	115/60/1	115/60/1	220/50/1	115/60/1	220/50/1
Full Load Amps - Cool	4.3	3.8	2.2	5.4	6.3	6.8	3.7	9.4	4.5
Locked Rotor Amperage	14.0	29.0	11.0	40.0	49.0	53.0	22.2	59.0	32.0
Refrigerant type	R-134A	R-417A		R-417A	R-417A	R-417A		R-417A	
Control type	Mechanical	Mechanical		Mechanical	Mechanical	Mechanical		Mechanical	
<b>Dimensions</b> ( $\pm 0.5''$ or 13mm)									
Height (in/mm)	9.50/241	11.75/298		11.75/298	13.50/343	13.50/343		13.50/343	
Width (in/mm)	9.75/248	9.50/241		9.50/241	9.75/248	9.75/248		11.00/279	
Depth (in/mm)	17.75/451	17.75/451		19.75/502	21.75/552	21.75/552		21.75/552	
<b>Connections</b>									
Sea Water (in/mm)	0.63/16	0.63/16		0.63/16	0.63/16	0.63/16		0.63/16	
<b>Estimated Weight</b> <sup>(1)</sup>									
Net weight (lbs/kg)	25.0/11.3	39.0/17.7		45.0/20.4	54.0/24.5	54.0/24.5		60.0/27.2	
Ship weight (lbs/kg)	32.0/14.5	50.0/22.7		TBD	TBD	TBD		72.0/32.7	

**Notes:**

<sup>(1)</sup> Weights listed are for ECM units only and do not include kit components.

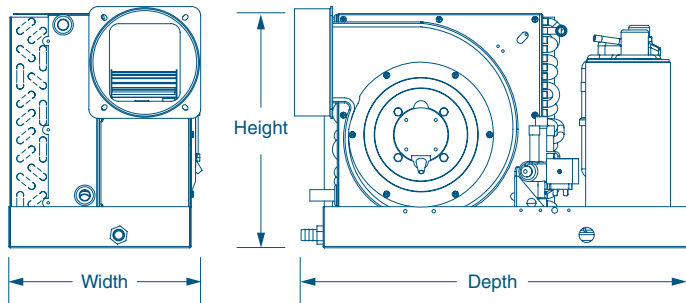

## Dual-Duct Kit

For applications requiring an additional air outlet, Dometic's dual-duct kit is available for 6.5-15K BTU/hr EnviroCool models.

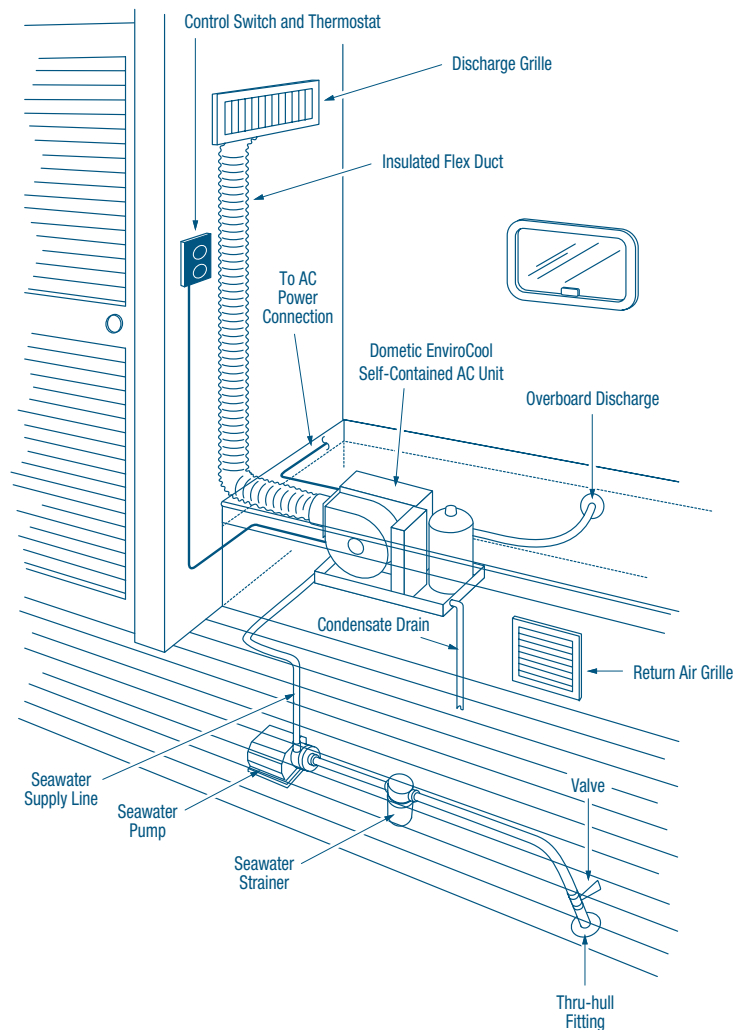

## DOMETIC MARINE DIVISION

2000 N. Andrews Ave. Ext. I Pompano Beach, FL 33069 USA | 954-973-2477 | Fax 954-979-4414  
www.DometicUSA.com | MarineSales@DometicUSA.com

### 24/7 Tech Support for United States & Canada:

8:00 AM to 5:00 PM Eastern Time: 800-542-2477  
After hours and weekends: 888-440-4494

### International Sales & Service:

Europe & the Middle East: Call +44(0)870-330-6101  
For all other areas visit our website to find your nearest distributor.



Dealer: