

SHURFLO® 4728 SERIES PUMPS

UTILITY PUMP

MODEL SERIES 4728

SHURFLO offers various pumps models for different applications. The information outlined by this manual is general, and not specific to all 4728 series pumps. Contact SHURFLO or your local distributor for specific application information and pump selection. SHURFLO always recommends professional installation and service of pumps and accessories.

CAUTIONS

■ "Intermittent Duty" is defined as: operated and/or frequently started within a period of time that would **NOT** cause the motor to reach its maximum thermal limits. Once the maximum thermal limit is obtained, the motor must be allowed to return to ambient temperature before resuming operation.

■ **DO NOT** use to pump flammable liquids. Never operate the pump in an explosive environment. Arcing from the motor brushes, switch or excessive heat from an improperly cycled motor may cause an explosion.

■ **DO NOT** assume fluid compatibility. If the fluid is improperly matched to the pumps' elastomers, a leak may occur. Pumps used to transfer hazardous or hot (max. temperature 120°F [49°C]) chemicals must be in a vented area to guard against the possibility of injury due to harmful or explosive liquid/vapors.

■ **DO NOT** operate the pump at pressures which cause the motor to exceed the amperes rating indicated on the name plate. Various pump models are equipped with thermal breakers to interrupt operation due to excessive heat. Once the temperature of the motor is within proper limits it will automatically reset, and the pump will start operation without warning.

MOUNTING

The 4728 series pumps are self-priming. Horizontal and vertical prime vary depending on the fluid viscosity and pump configuration. The pump should be located in an area that is dry and provides adequate ventilation. If mounted within an enclosure, provisions to cool the motor may be necessary. Heat sinks which attach to the motor are available from SHURFLO if increased heat dissipation is necessary.

CAUTION

DO NOT locate the motor near low temperature plastics or combustible materials. The surface temperature of the motor may exceed 250°F [120°C]. The pump may be mounted in any position. However, if mounting the pump vertically the pump head should be in the down position so that in the event of a leak, fluid will not enter the motor. **DO NOT** compress the feet, doing so will increase vibration and noise.

PLUMBING

Flexible high pressure tubing compatible with the fluid should be used to connect the inlet/outlet ports. Tubing should be at least ½" [13 mm]. Restrictions on the inlet may cause vacuum levels to reach the fluid vapor pressure, causing cavitation, degassing, vapor lock, noise, and a loss in performance. Inlet pressure must not exceed 30 psi [2.1 bar] maximum. Installation of a 50 mesh strainer is recommended to prevent foreign debris from entering the pump. If a check valve is installed in the plumbing, it must have a cracking pressure of no more than 2 psi [.14 bar].

ELECTRICAL

Electrical wiring should be performed by a qualified electrician, in accordance with all local electrical codes. The pump should be on a dedicated (individual) circuit, controlled with a switch (double pole VAC U.L./C-UL certified) rated at or above the fuse ampere indicated by the pump motor label. All 115 VAC and 230 VAC pump motors and systems **MUST** be grounded per local and state electrical codes. For the pump to meet U.L./C-UL requirements the circuit **MUST be protected with a slow-blow fuse** (U.L./C-UL certified) or equivalent circuit breaker as indicated on the motor label. Use an approved wire of the size specified or heavier.

Ft. [m]		AWG [mm ²]	
0-25	[0-7.6]	16	[1.3]
25-50	[7.6-15.2]	14	[2.1]
50-70	[15.2-21.3]	12	[3.3]
70-110	[21.3-33.5]	10	[5.3]

Minimum Wire Size for a 10% voltage drop on a 12VDC, 15 Amp Circuit. Length is the distance from the power source to pump and back to ground.

SERVICE

Kits are readily available to repair standard 4728 series pumps. Repair kits include simple illustrated instructions allowing easy installation. To insure that the correct kit is received the model numbered and all name plate data must be included with the order. Visit our web site, contact a SHURFLO distributor or contact SHURFLO directly to order the necessary repair kits.

CAUTION

To prevent electrical shock, disconnect power before initiating any work. In the case of pump failure, the motor housing and/or the pumped fluid may carry high voltage to components normally considered safe.

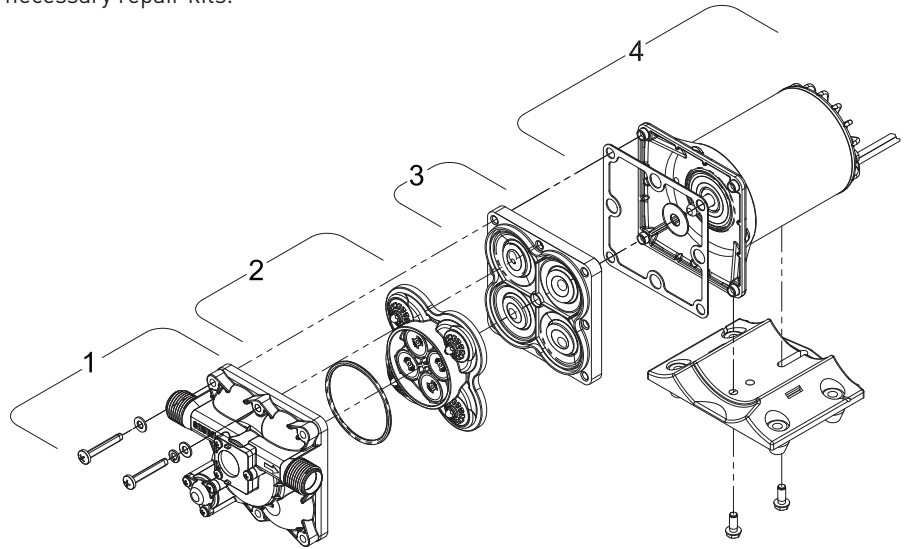

SERVICE KITS

ITEM	DESCRIPTION	PART NUMBER
1	Upper Assembly	94-800-31
2	Valve Assembly	94-800-01
3	Drive Assembly	94-800-25
4	Motor/Gasket	94-71-007-07
1, 2, 3	Pump Head	94-800-30
Not Shown	Check Valve	94-800-03



FLOW MANAGEMENT SOLUTIONS

3545 HARBOR GATEWAY SOUTH, SUITE 103, COSTA MESA, CA 92626, (800) 854-3218 WWW.SHURFLO.COM

All Pentair trademarks and logos are owned by Pentair, Inc. All other brand or product names are trademarks or registered marks of their respective owners. Because we are continuously improving our products and services, Pentair reserves the right to change specifications without prior notice. Pentair is an equal opportunity employer.