

Installation: Refer to figure-1. Install the seacock in accordance with ABYC H-27 onto a backing block of suitable material for wet bilge areas. The backing block serves to further spread the load, but not directly on the hull section through which the thru-hull fitting penetrates. Some installers prefer bolting through the hull and backing block, while others will bond the backing block permanently to the hull, and then bolt into the backing block, but not all the way through the hull. Either installation is acceptable.

Depending on the combined backing block + hull thickness, the thru-hull fitting length may need to be reduced so it does not bottom out inside the seacock before proper compression is achieved.

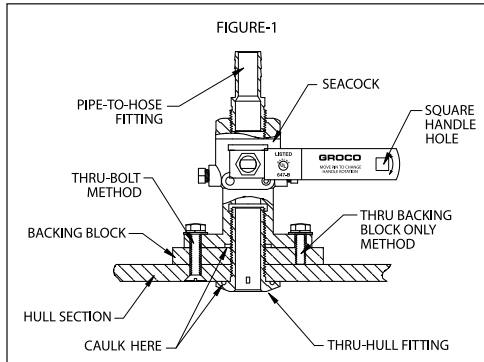

Changing Handle Position: GROCO SBV seacocks allows the installer to change handle position, from one side of the valve to the other. This feature provides uniformity of installation and eliminates confusion in valve operation (for example, port and starboard valve handles may both close by moving them aft). To change handle position, first close the seacock. Refer to the Exploded View Drawing. Remove one item-8, item 9, 10, 23 and 13-16. From the opposite side remove items 11 and 12. Re-install the items removed from each side into the opposite side IN THE SAME ORDER shown in the exploded view drawing. Install Note: Apply a drop or two of Loc-Tite® Threadlocker #243 to the threads of items 10 and 11 during re-installation.

Square Handle Hole: GROCO SBV seacock handle has a square hole that will accept a standard ratchet extension. Use this feature to break loose a stuck valve or to reach the handle in an inaccessible location. Exercise caution when operating the valve with a ratchet handle attached as the added length provides a mechanical advantage that could damage the valve handle.

Bonding: The seacock base has a bonding screw. Use at least 14ga marine grade stranded copper wire to connect the seacock to the vessel bonding system. Bonding may be made in series with other non-motorized equipment such as strainers. **WARNING: DO NOT bond motorized equipment such as air conditioner pumps in series with the seacock. Motorized equipment must have a separate connection to the vessel AC or DC grounding bus, in accordance with ABYC E-11, Figure-18.**

Normal Operation: The valve is closed when the handle is horizontal (perpendicular to the thru-hull fitting) and is open when vertical (parallel to the thru-hull fitting).

Emergency Operation: In an emergency or if bilge level is above the SBV side port, close the seacock and remove the Quick-Release Plug (1/4-turn CCW). With the connected engine running, excess water will be drawn through the open side port and pumped overboard through the exhaust system. Note: Monitor the bilge level around the SBV. If the level falls below the side port you no longer have an emergency, and the engine raw water pump will be running dry. Re-install the Quick Release Plug (1/4-turn CW) and open the seacock to allow outside water to be drawn into the cooling system. **WARNING: DO NOT open the seacock without first re-installing the Quick Release Plug; bilge flooding will result.**

Bilge Maintenance Operation: The SBV side port is designed to accept BSA Bilge Strainer Adaptor Kit. BSA consists of a barbed adaptor that fits into the side port, a bilge strainer, and a 90-degree pipe/hose fitting. The bilge strainer is installed in the deepest or most inaccessible bilge area, with a hose connection to the SBV location. To pump out the remote bilge location, close the seacock, remove the Quick Release Plug, and insert the BSA adaptor. Start the connected engine; bilge water will be drawn and pumped overboard through the exhaust system. Note: Monitor the bilge level in the remote bilge area. If the level falls below the Bilge Strainer openings, the engine raw water pump will be running dry. Shut off the connected engine, remove the adaptor and reinsert the Quick Release plug before opening the SBV. **WARNING: DO NOT open the seacock without first re-installing the Quick Release Plug; bilge flooding will result.**

Winterization: Freezing may damage the seacock and connected plumbing if left filled with water. In freezing conditions, close the seacock and drain the water from the valve by removing the Quick Release Plug. Replace the Quick Release Plug after draining.

Connections: GROCO offers a complete line of straight and 90-degree cast bronze pipe/hose fittings in full flow (FF or FFC) or standard flow (PTH or PTHC) models to complete your installation. Use TFE thread tape on threaded connections; double clamp hose connections.

Maintenance: No regular maintenance is required. It is recommended that the valve be operated at least monthly to assure free movement and to prevent the build-up of nuisance marine growth. If service is required, GROCO SBV series seacocks allow in-field disassembly. Remove the cap screws (Exploded View Item-2) that secure the top nut. The nut can now be unscrewed to allow access to the ball and seats. Stem seals are accessible from outside the valve by removing the handle and stem lock nut.

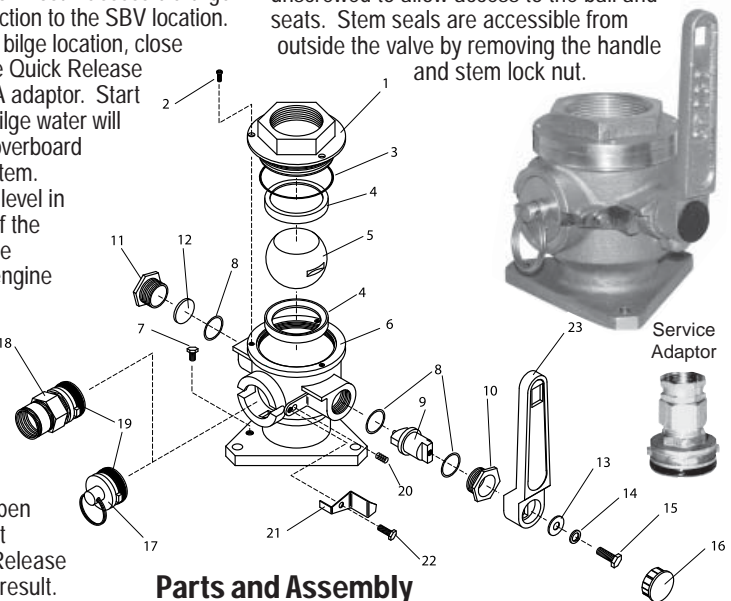

Parts and Assembly

ITEM	NAME	QTY	SBV-1250	SBV-1500	SBV-2000	SBV-2500	SBV-3000
1	Top Nut	1	BV-1252	BV-1502	BV-2002	BV-2502	BV-3002
2	Screw	3	632x38SOC	632x38SOC	-	-	-
3	Screw	4	-	-	632x38SOC	632x38SOC	632x38SOC
4	O-Ring	1	2-135	2-140	2-150	2-154	2-157
5	Seat	2	BV-1256	BV-1506	BV-2006	BV-2506	BV-3006-1
6	Body	1	SBV-1250-BT	SBV-1500-BT	SBV-2000-BT	SBV-2500-BT	SBV-3000-BT
7	Screw	1	1420X38HS	1420X38HS	1420X12HS	1420X12HS	1420X12HS
8	Seal	3	1-017	1-116	1-116	1-118	1-118
9	Driver	1	BV-1001-A	BV-1501-A	BV-1501-A	BV-2501-B	BV-2501-B
10	Nut	1	BV-1003-A	BV-1503-A	BV-2003-A	BV-2503-A	BV-2503-A
11	Nut	1	BV-1003-A	BV-1503-A	BV-1503-A	BV-2503-A	BV-2503-A
12	Seal	1	SBV-1250 Plug	SBV-2000 Plug	SBV-2000 Plug	SBV-3000 Plug	SBV-3000 Plug
13	Washer	1	14FS	38FS	38FS	38FS	38FS
14	Lockwasher	1	14SS	38SS	38SS	38SS	38SS
15	Bolt	1	1420X12HS	3816X58HS	3816X58HS	3816X58HS	3816X58HS
16	Cap	1	PFW-11	PFW-12	PFW-12	N/A	PFW-10
17	QR Plug Assy	1	SBV-1255	SBV-1505	SBV-2005	SBV-2505	SBV-3005
18	Service Adaptor	1	SBVSA-1255	SBVSA-1505	SBVSA-2005	SBVSA-2505	SBVSA-3005
19	O-Ring	2	2-118	2-120	2-128	2-136	2-144
20	Spring	1	07-0001-00	07-0001-00	07-0001-00	07-0001-00	07-0001-00
21	Safety Stop	1	SBV-1259	SBV-1509	SBV-2009	SBV-2509	SBV-3009
22	Screw	1	1032X12HSS	1032X12HSS	1032X12HSS	1032X12HSS	1032X12HSS
23	Handle	1	BV-1008	BV-1508**	BV-1508**	BV-2508-A**	SBV-3008-A

** If upgrading to handle with ratchet capability, we suggest you remove the handle for part number on back. Due to modifications between '04 -'05, part number could be SBV vs BV depending on manufacturing date.