



**Installation & operating instructions  
Isotherm INOX marine refrigerators  
Type: DR 49 & DR 65**

Indel Webasto Marine USA  
Telephone (800) 422-9711  
E-mail: [info@indelwebastomarineusa.com](mailto:info@indelwebastomarineusa.com)  
[www.indelwebastomarineusa.com](http://www.indelwebastomarineusa.com)



# Installation & operating instructions

## Table of contents

- 1 Introduction
    - 1.1 General
    - 1.2 Safety and precautions
    - 1.3 Environmental markings
  - 2 Operation
    - 2.1 Temperature setting thermostat
    - 2.2 User tips
    - 2.3 Defrosting
  - 3 Maintenance
    - 3.1 Battery voltage sensor
  - 4 Installation instructions
    - 4.1 Ventilation
    - 4.2 Door front
    - 4.3 Electrical connections
    - 4.4 Electrical wire dimensions
    - 4.5 Inner light
    - 4.6 Wiring diagram
  - 5 Technical data
  - 6 Trouble shooting
  - 7 Installation dimensions
-

# 1. Introduction

## 1.1 General

Isotherm refrigerators are specially designed to operate in tough marine environments. They are fitted with a fully hermetic, leak-free compressor, they offer the lowest possible power consumption and noise level. All models are simple to install. They can withstand an angle of heel up to 30°, for a short time. To ensure that your Isotherm fridge operates as efficiently as possible, please follow these general guidelines:

- Unnecessary opening of the fridge door will increase power consumption.
- Good ventilation of the compressor and condenser unit will reduce power consumption.
- The electrical system should be in good condition. Inspect batteries and charging levels regularly. Always use a separate starter battery for the engine. Follow carefully the guidelines regarding electrical cable areas and fuse placements.
- Keep the inside of the fridge and freezer clean and dry. Remove any water from condensation that may have collected in the drip tray.
- Keep the door slightly open to air the refrigerator when leaving the boat for any length of time.
- Clean the inside of the refrigerator with lukewarm water and a mild detergent before taking the fridge into operation the first time.

## 1.2 Safety and precautions

For your own and others safety, read this first.



**Danger!** When connected to mains power, ensure that the power supply is equipped with an earth safety automatic switch, a "ground fault circuit interrupter".



**Danger!** Never touch bare electrical wiring connected to the AC power supply. Do not use the device if the connector cables show visible damage. Never connect battery charger direct to the refrigeration system. A battery charger **must** be connected to the battery, never direct to the refrigeration system. **Danger!** In addition to acid, a newly-charged battery contains explosive gas. Never cover the ventilation openings for the compressor unit. Refrigerant may never be let out in the air. Repair of the refrigeration circuit must be done by a certified technician.

## 1.3 Environmental markings

This appliance is marked according to the European directive 2002/96/EC on Waste Electrical and Electronic Equipment (WEEE). By ensuring this product is disposed of correctly, you will help prevent potential negative consequences for the environment and human health, which could otherwise be caused by inappropriate waste handling of this product.

The symbol  on the product, or on the documents accompanying the product, indicates that this product may not be treated as household waste. Instead it shall be handed over to the applicable collection point for recycling of electrical and electronic equipment. Disposal must be carried out in accordance with local environmental regulations for waste disposal. For more detailed information about treatment, recovery and recycling of this product, please contact your local city office, your household waste disposal service or the shop where you purchased the product.



## 2. Operation

The refrigerators are made for use at ambient temperatures between 0°C/32°F and +42°C/107°F.

### 2.1 Temperature regulation thermostat

The refrigerator is fitted with a manually operated thermostat. This is turned clockwise to reduce temperature and anti-clockwise to both increase temperature and activate the on-off switch at the end position, 0-position. A certain spring resistance is recognized at the off position.

It is advisable to start with the thermostat in a medium position. It is advisable to keep a temperature of 5-6°C/ 41-43°F inside the refrigerator. Higher temperatures will reduce storage time.

The ambient temperature influences the temperature also inside the fridge. Avoid direct sunshine and other heat sources close to the refrigerator.

The thermostat control knob is placed inside the refrigerator, see description below.



Thermostat inside on vertical wall.

### 2.2 User tips

- Load the food inside the refrigerator in such a way, air can circulate to equalize the temperature.
- Do not cover the shelves with glass or paper etc.
- To reduce the amount of ice building up in the evaporator, cover all liquids and moist food.
- Let all hot foods cool well before putting them into the refrigerator.

### 2.3 Defrosting

The evaporator is working on below freezing temperatures and will form frost and ice from humidity in the air. The humidity increases with higher outside temperature, with storage of non sealed fresh food and liquids and the time the door is kept open. Defrosting shall be made when the frost layer is more than 4 mm / 1/8" thick.

Set the thermostat in OFF position or switch off on the ASU control panel. Store the foodstuff and the liquid as cold as possible during the defrosting process.

**Do not use sharp metal tools to remove frost or ice.** Do not re-start until the refrigerator is completely defrosted, cleaned and dried. Empty and clean also the plastic drip tray below the evaporator. Place towels in the bottom of the refrigerator to collect melt water.

## 3. Maintenance

The Isotherm DR refrigeration systems have a fully hermetic closed cooling system and do not require any maintenance or refilling of refrigerant.

The compressor is of mobile type and has a very high efficiency and an outstanding life-time. The refrigerator shall be left in the boat during the winter. (If the temperature is below freezing point, the compressor may not start). The maintenance is reduced to periodically, not less than a year, cleaning of the condenser from dust. Use a soft brush and no sharp tools. Keep the cabinet inside clean. Use lukewarm water and a mild detergent for cleaning the inside. Put the doors, during not in operation periods, in their slightly open ventilation position.

### 3.1 Battery voltage sensor

To protect the batteries from becoming completely discharged, a battery voltage sensor switches off the compressor automatically at the following levels:

System voltage V	Cut out V	Cut in V
12	9.6 (10.4)	10.9 (11.7)
24	21.3 (22.8)	22.7 (24.2)

If the bridge between C and P is cut off, values within the ( ) are valid.

## 4 Installation instructions

Many boats have a space which is intended for a fridge. The Isotherm Cruise fridge has been designed to suit the general dimensions normally used for this purpose.

The compressor should normally stand upright in the boat, but will operate at an angle of heel up to 30° and for short periods even more.

The INOX type refrigerators have a flush mounting frame, three side frame, as standard.

### 4.1 Ventilation

It is very important that the compressor/condenser unit is well ventilated and that cold air can enter at the bottom, pass behind the fridge and warm air can leave at the top in the area where it is mounted. The natural flow of air from below and upwards behind the fridge can be increased by arranging ventilation openings at the rear.

Make sure there is a free area of 100-150 cm<sup>2</sup> / 15 - 23 sq.in. below and behind the refrigerator to allow ventilation air to pass behind from below.

See fig.

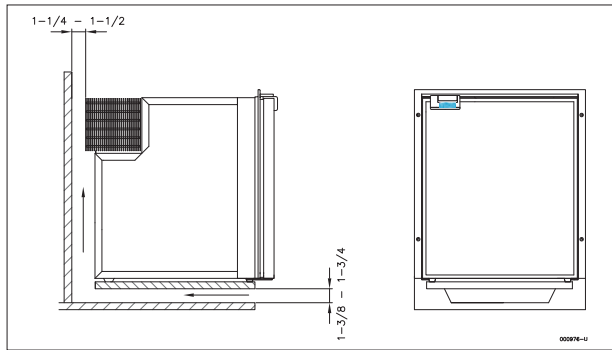

## 4.2 Door front panel

The INOX models have doors in stainless steel and do not have exchangeable door fronts.

## 4.3 Electrical connections/wiring

When connecting the refrigerator electrically, it is important that following points are considered: Always use cables of sufficient area. The area in the following table should be regarded as a minimum.

\* Always connect the refrigerator directly to the battery or to the battery main switch on the plus circuit. Do not connect it via the boats own control panel or other diversions as this can cause a voltage drop in the power supply. Use the included fuse holder with a 15A fuse. Use 7.5A fuse in a 24 volt system. The fuse shall be mounted on the plus cable.

- \* Connect the red cable to the positive (+) terminal and the black to the negative (-) terminal. Use tab type terminals for the connection to the electronic unit and other cable connectors of sufficient size for the cable size selected.
- \* Do not connect the refrigerator direct to a battery charger. The battery charger must be connected to the battery.

## 4.4 Wire dimensions

Cable area mm <sup>2</sup>	Wire gauge #	Max cable length in m/ft. 12V	Max cable length in m/ft. 24V
2.5	12	2,5 / 8	5 / 16
4	12	4 / 13	8 / 26
6	10	6 / 33	12 / 66

## 4.5 Inner light

The refrigerators have inner light (LED) mounted in the top of the cabinet.

## 4.6 Wiring diagram

12-24 VDC

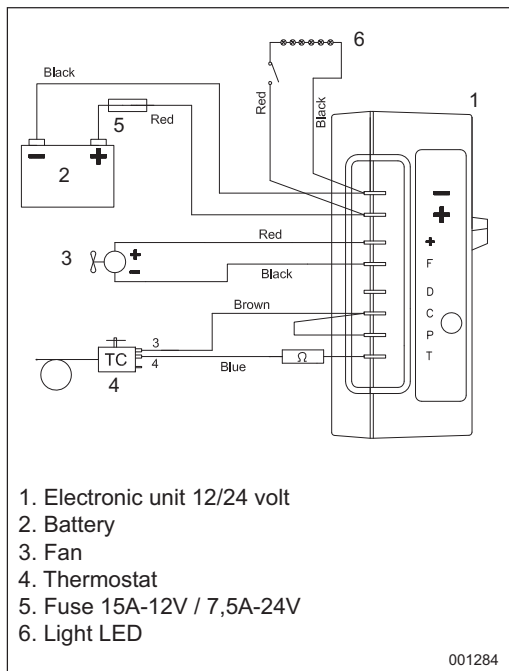

AC/DC, 100-240 VAC & 12-24 VDC

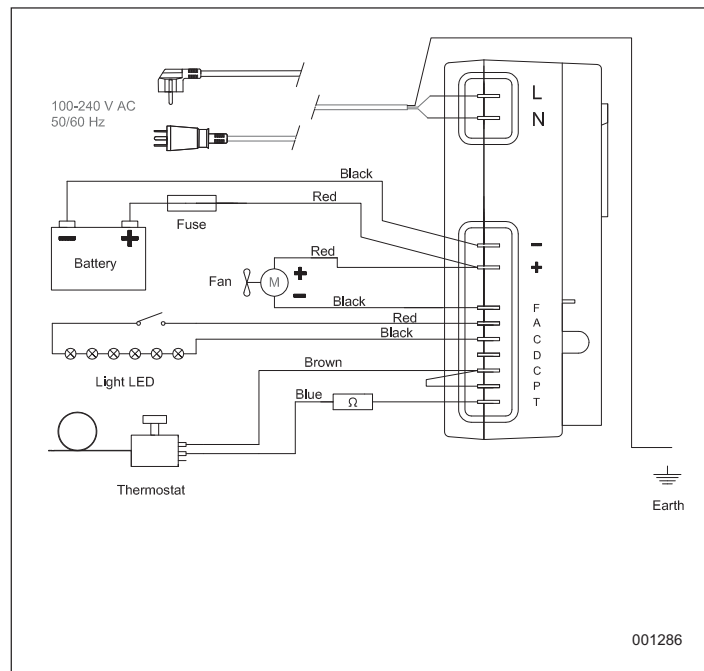

## 5 Technical data

Voltage	12 or 24 volt DC / 100-240 volt AC
Power consumption when compressor is running:	DR 49 & 65: 5 A at 12 V (half at 24 V)
Average consumption:  Average consumption measured at +6°C/43°F in the refrigerator and 22°C/72°F ambient temperature. The average consumption is much dependent on the way the fridge is used and how well the ventilation is working.	DR 49: 0,8 A at 12 V DR 65: 0,9 A at 12 V
Compressor:	Danfoss BD35F
Refrigerant:	R134a, filling amount is printed on the sticker inside the fridge.
Fuse:	15 A for 12 volt or 7,5 A for 24 volt respectively.

Isotherm refrigerators fulfil valid EMC directives and are CE-marked.



## 6 Fault finding

Fault	Possible cause	Action
Fridge not cold, compressor will not start.	No power supply. Battery in poor condition. Faulty thermostat. Faulty electronic unit.	Check that power is present at electronic unit. Check fuse. Check polarity on connectors and cables. Bridge the thermostat over T-C, see wiring diagram. If compressor starts, this indicates a faulty thermostat. If the compressor does not start, this indicates a faulty electronic unit or compressor. Contact an authorized service agent. A possible leak in the cooling system, contact an authorized service agent.
Compressor makes only short start attempts.	Bad power supply, too low voltage or voltage drop at start attempts. Discharged batteries.	Check cables, terminals and other connections, possible verdigris or corrosion, Clean. Charge batteries, run the engine or connect a battery charger. Voltage must be kept above 11.0 V at start attempts.
Compressor runs but no refrigeration generated.	Loss of refrigerant. Leakage in pipes or evaporator. Pipes blocked.	Pressure and leak test. Check for pipe damages. Repair possible leak, evacuate and re-fill refrigerant. (All this to be made by refrigeration specialist).
Compressor runs long time but not generating enough cold.	Bad ventilation. Condenser too warm. Cooling fan not working Too much frost on evaporator. Door not closing well. Condenser blocked by dust.	Improve ventilation for compressor. Re-place fan. Defrost. Check/adjust door position and door seal. Clean condenser.
Fuse blows.	Wrong fuse size. Faulty electronic unit.	Check fuse, 15 A-12 V / 7,5 A-24 V Exchange electronic unit.

If a complicated fault does occur, such as requiring specialist assistance, please contact Indel Webasto Marine S.r.l. Italy or your local marine distributor for advice.

## 7 Installation dimensions

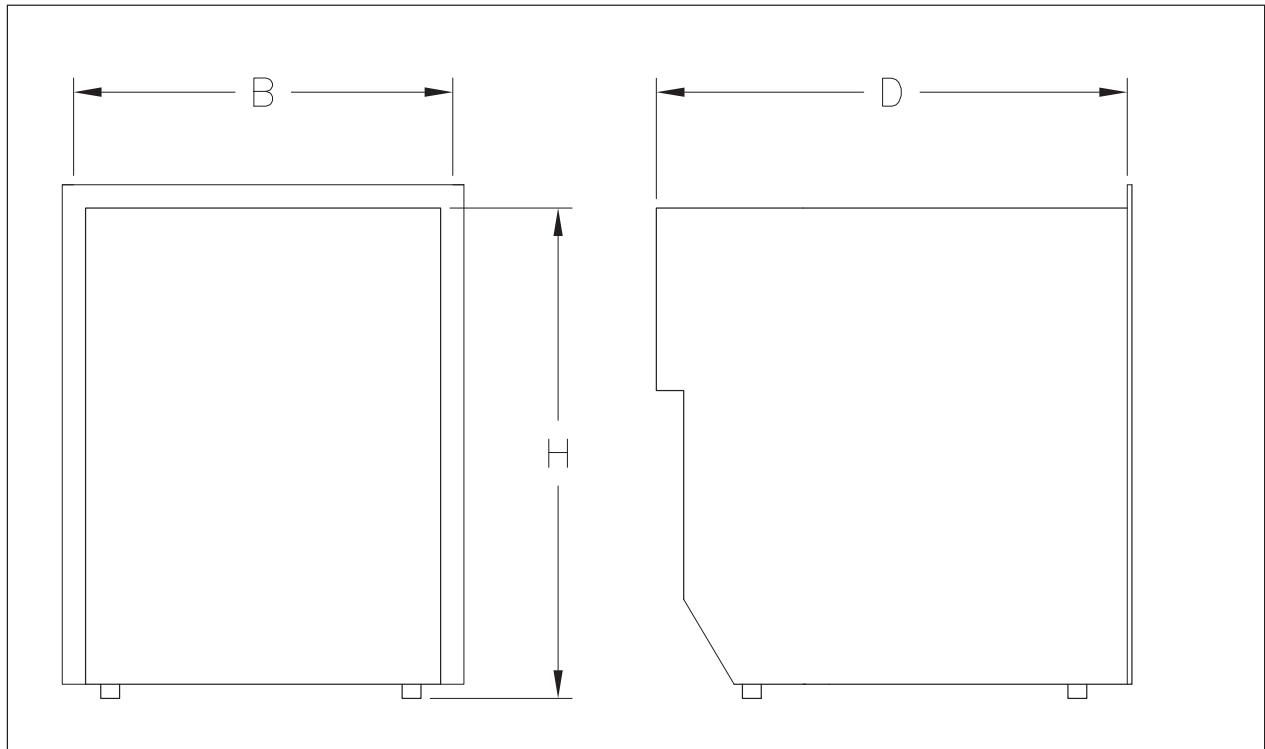

Type	B *	H *	D	D - AC/DC
DR 49 INOX	400	530	510	530
DR 65 INOX	470	530	530	550

\*) B x H = day opening, min dimensions

More detailed drawings of the refrigerators can be seen on: [www.indelwebastomarine.com](http://www.indelwebastomarine.com)

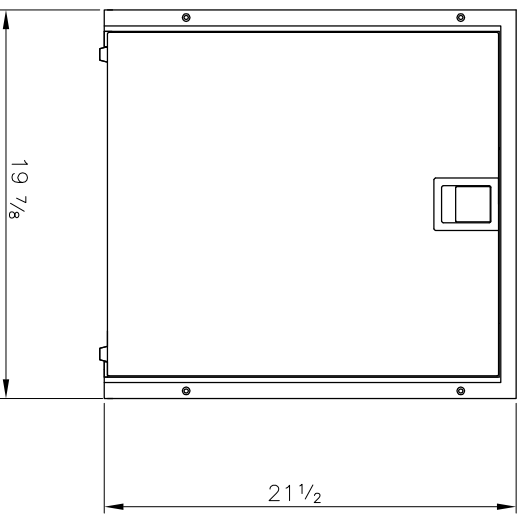
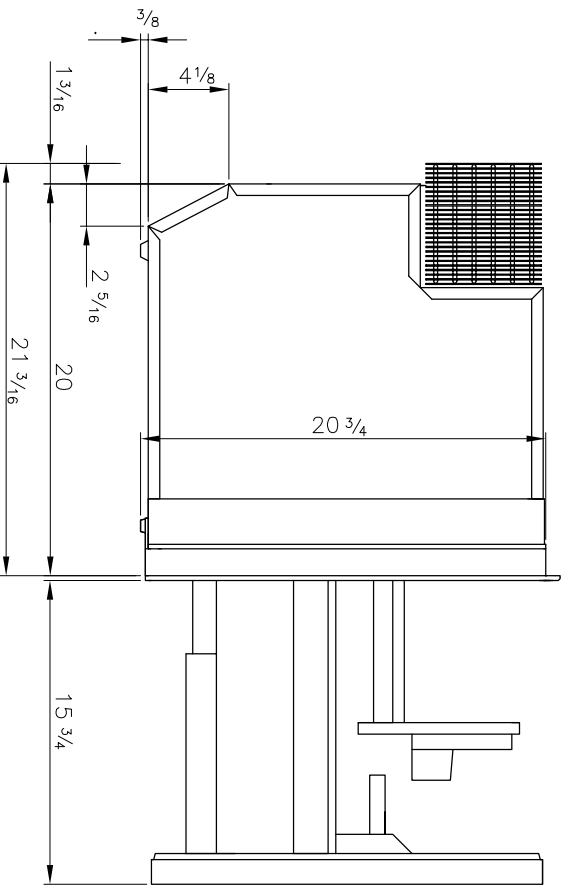
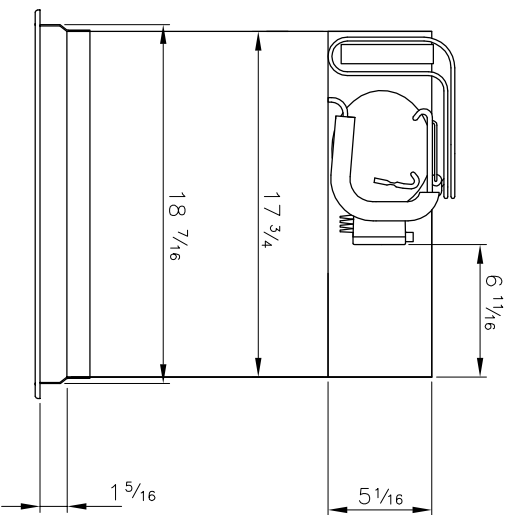

RevNo Revision note

Date

Signature Checked

Item no	Quantity	Title/Name, designation, material, dimension etc	Article No./Reference	Scale
Designed by	Checked by	Approved by - date	Revision	Date
Owner				



Title/Name  
Isotherm DR65 INOX

Drawing number  
DR65 INOX

Edition  
U

Sheet



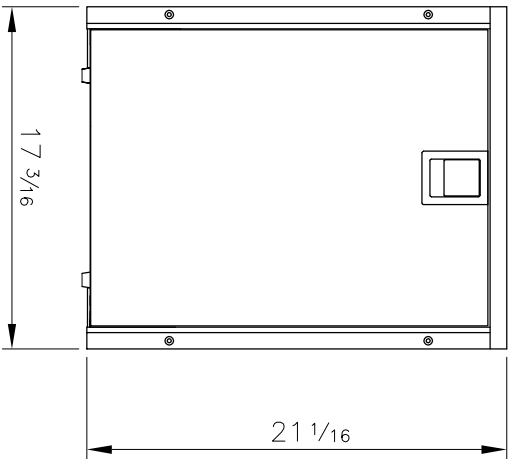
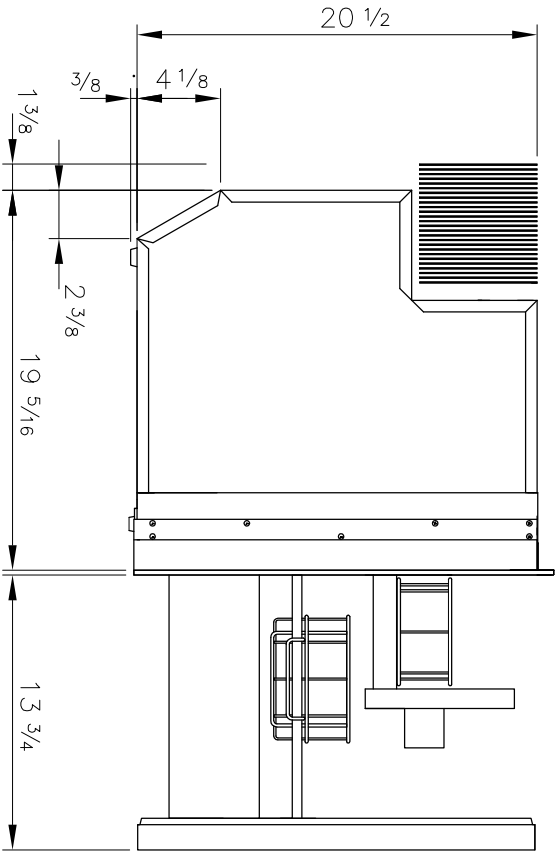
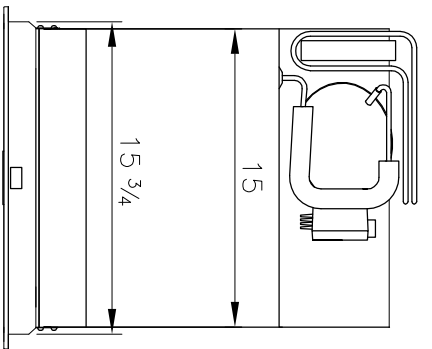

RevNo	Revision	note	Date	Signature	Checked

Owner	Quantity	Qty/Name, designation, material, dimension etc	Article No./Reference
Designed by	Checked by	Approved by - date	Date
		Released	Scale
			080103/LLG
<b>isotherm</b> <small>ISO 9001 CERTIFIED COMPANY</small> <small>ISO 14001 CERTIFIED COMPANY</small>		Qty/Name Isotherm DR 49 INOX	Edition U
Drawing number DR49 INOX		Edition U	Sheet 1