

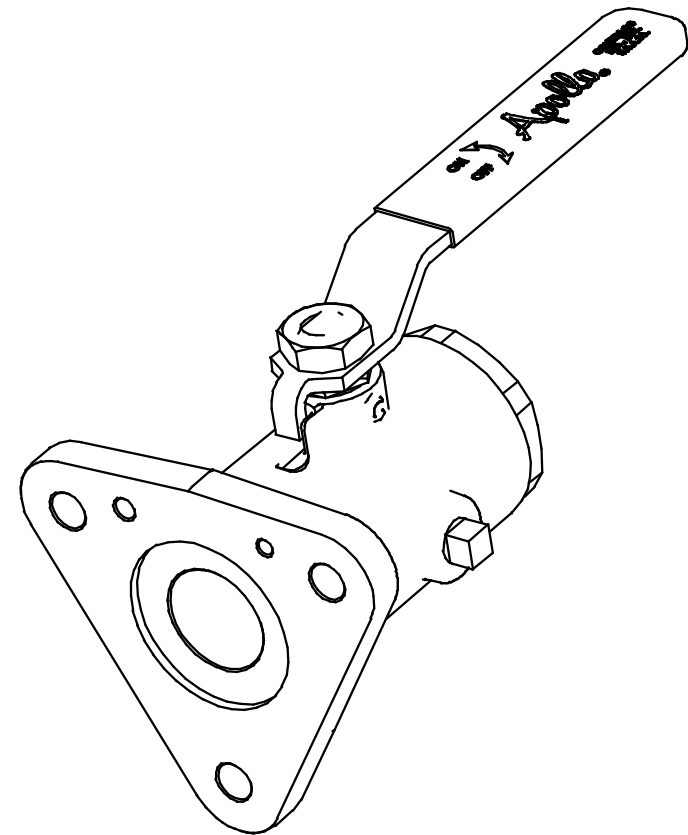

A Division of Conbraco Industries, Inc. Matthews, NC Pageland, SC Conway, SC

SEA FLANGE BALL VALVES INSTALLATION, OPERATION, & MAINTENANCE GUIDE



INSTALLATION

Valves must be installed in compliance with A.B.Y.C Standard H-27 (Sea Cock, Thru-Hull Fittings, and Drain Plugs). The valve installation must be in conformance with A.B.Y.C. E-2 (Cathodic Protection) for proper protection.

Flange End Installation

Valve mounting surface should be clean and smooth. Mark and drill mounting holes and through holes before mounting the Sea Flange valve. Provide adequate sealing compatible with the Sea Flange valve and mounting surface. Use appropriate mounting hardware for the mounting surface. Attach bonding system to screws provided.

Threaded End Valves

Pipe connections to be threaded into these valves should be accurately threaded, clean and free of foreign material or metal shavings. PTFE pipe tape is recommended for use as the pipe joint sealant. Two wrenches must be used when making up pipe joints to these valves. Apply one wrench on the valve end closest to the pipe joint being tightened and the other wrench to the pipe to prevent transmitting torque through the valve body joint. Typical pipe make-up is 1-1/2 turns after installing the pipe hand-tight.

OPERATION

The valve handle is marked showing proper rotation direction for "ON" and "OFF" positions. Rotation is clockwise for "OFF" (closed) and counterclockwise for "ON" (open).

MAINTENANCE

Regular Maintenance

Normal stem packing wear can be compensated for by tightening the packing gland screw. (Wrench part number H371400 is available to ease this operation.) Tighten the packing gland screw clockwise in 1/8 turn increments until observed leakage stops. If all of the adjustments to the packing gland screw have been made, remove the handle nut, handle and packing gland screw and add one or two replacement bearings on top of the old packing. Reinstall the handle and handle nut.

Caution: Do not disassemble valve while under pressure nor with entrapped hazardous fluids therein.

Lubrication

No lubrication is needed during normal operating conditions.

Winterizing

Marine valves are equipped with a drain port to drain water from the valve prior to freezing conditions. Valves should not be in service if the drain plug is removed.

Seal Replacement

Seal replacement is not recommended. Replace the Marine valve if unacceptable leakage occurs.

Note: Always test valve and system before putting the system into service.

Warning: (Required by California) This product contains a chemical known to the state of California to cause Cancer and Birth Defects or other Reproductive Harm.

PARTS ILLUSTRATION

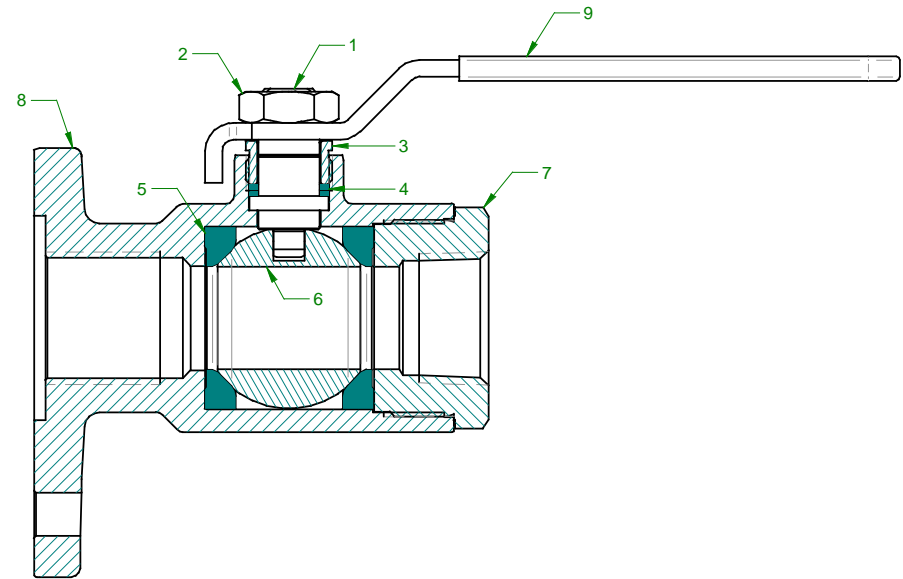

NO	DESCRIPTION
1	STEM
2	STEM NUT
3	PACKING GLAND SCREW
4	PACKING
5	SEAT
6	BALL
7	RETAINER
8	BODY
9	HANDLE
10	GROUNDING SCREWS (NOT SHOWN)