

Visit ProMariner online at [www.promariner.com](http://www.promariner.com), for a complete selection of quality marine products...

Here are just a few:

- ProMite Series - Recreational Grade Waterproof Marine Battery Chargers
- ProSport Series - Heavy Duty Recreational Grade Waterproof Marine Battery Chargers
- ProTournament Series - Professional Grade Tournament Waterproof Marine Battery Chargers
- ProlsoCharge Series - Digitally Controlled Zero Loss Charging Isolators
- Digital Mobile Charge In-Transit Chargers
- Battery Maintainers
- AC Plug Holders
- Battery Isolators
- Isolation Transformers
- Galvanic Isolators and Monitored Systems
- Corrosion Control Products
- Waterproof Marine Binoculars
- Gold Plated Fuses and Holders
- A Complete Line of Hand Held Test Meters
- Online Technical Support and Service Support

Visit frequently, we are always adding new products for your boating enjoyment!

Professional Mariner, LLC  
 200 International Drive, STE 195  
 Portsmouth, New Hampshire 03801  
 TEL: 603-433-4440  
 FAX: 603-433-4442  
[www.promariner.com](http://www.promariner.com)

specifications subject to change without notice

04/11 A

# ProMariner™



## ProIsoCharge Series Instruction Manual

Models	Part No.	Volts	Amps	Alternator Input	Battery Output
ProlsoCharge120 1•2	23121	12	120	1	2
ProlsoCharge180 1•2	23122	12	180	1	2
ProlsoCharge120 1•3	23124	12	120	1	3
ProlsoCharge250 1•2	23123	12	250	1	2
ProlsoCharge180 1•3	23125	12	180	1	3
ProlsoCharge250 1•3	23126	12	250	1	3
ProlsoCharge130 2•4	23127	12	130	2	4
ProlsoCharge60 1•2	23241	24	60	1	2
ProlsoCharge100 1•2	23242	24	100	1	2
ProlsoCharge60 1•3	23245	24	60	1	3
ProlsoCharge150 1•2	23243	24	150	1	2
ProlsoCharge100 1•3	23246	24	100	1	3
ProlsoCharge150 1•3	23247	24	150	1	3
ProlsoCharge80 2•4	23248	24	80	2	4

### IMPORTANT NOTICE

This manual contains important safety and operating instructions for the ProIsoCharge Series. Please save and read all safety, operating and installation instructions before installing your ProIsoCharge unit.

### Your Satisfaction is Important to Us!

Do not return this product to retailer or dealer for any service or warranty requirements. Please call our Customer Care Department at 800-824-0524 from 8:30 am to 5 pm Eastern Time for any warranty, service or installation assistance. Thank you - ProMariner Customer Care

### PLEASE RECORD YOUR:

Model Number: \_\_\_\_\_ Serial Number: \_\_\_\_\_ Date of Purchase: \_\_\_\_\_

## Table of Contents

---

Introduction...	2
Important Safety Instructions...	2-6
Installation...	7-10
General Operation...	11
Maintenance...	12
Troubleshooting...	13
Warranty Information...	14

## Introduction

---

Congratulations on your purchase of your new ProMariner ProIsoCharge Advanced Digital Charge Distribution and Battery Isolation System. This unit offers the following features and benefits:

- Seamless charging of up to 4 battery banks

- 0.0% voltage drop insuring maximum charging capability

- Priority setting for the START battery to ensure a completely charged start battery isolation/back feed protection between battery banks to prevent banks from discharging neighboring banks

- High voltage protection in the event of a charging source malfunction

- High output protection to prevent overcharged banks from damaging neighboring banks

- Use on single alternators, dual alternators, single-bank chargers, solar or wind charge applications

- Waterproof housing contributes to long life and expanded installation options

### Unpacking And Inspection:

Thoroughly inspect your ProIsoCharge unit. The package should contain the following:

- 1) ProIsoCharge
- 2) Hard Plastic Terminal Cover
- 3) Rubber terminal cover boots
- 4) Parts package including:
  - a. Owners/Installation manual
  - b. Warranty Card

**DAMAGE – If any parts are missing or damaged, or the unit has been damaged in shipping contact ProMariner Customer Service at 1-800-824-0524, please do not take it back to place of purchase.**

**DO NOT attempt to install or operate the unit if it has been damaged in any way.**

### How Does This Unit Work?

The ProIsoCharge is installed between the charging source and multiple battery banks. The ProIsoCharge is activated by the ignition feed (key on position) indicating to the unit that charging will begin. When the unit is off, it draws no power. The unit will self-test on each start-up, and begin assessment of the connected batteries conditions.

Beginning with the Start Battery, the unit will charge to 13.3V and then begin charging the second bank and then the third. Once all banks are at least 13.3V, the unit brings all 4 banks on line for charging. This process could take seconds or minutes depending on the state of charge of each bank.

The solid state circuitry can also control backfeeding or when a heavy load such as a windless attempts to draw from a neighboring bank; the unit will direct the charge to the bank under load. After the bank under load is fully charged, the rest come on line.

There are many uses for the ProIsoCharge. ANY charging source such as a single output ProMariner Battery Charger or an alternative energy source such as a wind generator or solar panel can become a multi-bank charging system.

## Warning

**DO NOT attempt to install or operate the unit if it has been damaged in any way.**

**IMPORTANT NOTICE – PLEASE READ AND UNDERSTAND THIS MANUAL BEFORE INSTALLING YOUR PROISOCHARGE SERIES.**

This manual is written to assist in the installation of your new ProIsoCharge; however, since this is a permanent DC hardwired installation, ProMariner strongly recommends that a Certified Marine Electrical Technician® trained by the American Boat and Yacht Council (ABYC) perform the installation. The ProIsoCharge unit you have purchased was constructed to the safety standards of the ABYC to prevent fire and electrocution; the installation must conform to these same industry standards. For more information on ABYC, their Standards and Technical Information reports for Small Craft and to find a certified technician near you, visit [www.abyc.com](http://www.abyc.com).

**⚠ CAUTION:** To preclude a safety hazard, all existing DC electrical components (e.g. wire, fuses, circuit breakers, battery switches, and connections) must be inspected for proper condition prior to installation. Failure to confirm adequate condition and proper installation to ABYC standard E-11 AC & DC electrical systems on board boats may result in a dangerous condition and/or premature failure of this or other installed electrical components. Any and all areas of the existing system that are found not in compliance with ABYC E-11 must be replaced prior to installation.

**⚠ CAUTION:** If you are replacing an existing battery charger please disconnect the battery charger output cables from the existing charger AND the battery(s). Do not use existing cables if they are not in compliance with the sizes detailed in this manual. If you have any doubt about your ability to fuse and wire this unit correctly PLEASE refer to [www.abyc.com](http://www.abyc.com) for a list of certified electricians in your area that are qualified to perform this installation to the ABYC standards.

Designed, Constructed and Tested to:



### ⚠ WARNING: LOW VOLTAGE / ATTENTION : BASSE TENSION

ELECTRICAL BURN AND SPARK HAZARD. BEFORE OPENING DISCONNECT CHARGER CONNECTIONS AT BATTERY(S). (DANGER DE BRULURES ELECTRIQUE ET ETINCELLES). AVANT D'OUVRIER LA BOITE DECONNECTER LES CONNECTIONS ENTRE CHARGEUR ET BATTERIE.

### ⚠ WARNING / AVERTISSEMENT :

DO NOT EXPOSE TO RAIN OR SPRAY / NE PAS EXPOSER AUX INTEMPERIES

### ⚠ CAUTION:

- HOT SURFACES - TO REDUCE THE RISK OF BURNS, DO NOT TOUCH.
- RISK OF ELECTRIC SHOCK. NO USER SERVICEABLE PARTS. RETURN TO MANUFACTURER FOR SERVICING
- THIS CHARGER IS MEANT FOR CONTINUOUS DUTY
- IGNITION PROTECTED
- FOR MARINE USE

### ⚠ ATTENTION :

- SURFACES CHAUDE-NE PAS TOUCHER, RISQUES DE BRULURES
- RISQUE DE CHOCS ELECTRIQUE-RETOURNER AU FABRIQUANT POUR SERVICE.
- CE CHARGEUR EST FABRIQUE POUR LE DEVOIR CONTINU
- PROTÉGÉ CONTRE L'EXPLOSION
- POUR UTILIZATION MARINE

## Warning

**Before connecting to batteries read all instructions and cautionary markings on the battery charger and batteries. Do not discard this manual, save it for future reference.**

**1. SAVE THESE INSTRUCTIONS** - This manual contains important safety, operating and installation instructions for the ProIsoCharge Series. **Do not discard this manual, save it for future reference.**

2. Do not expose to rain or snow.
3. Use of attachments not recommended or sold by Professional Mariner, LLC will void warranty and may result in a risk of fire, electrical shock or personal injury.
4. Do not operate the charger if it has received a sharp blow, direct hit of force, been dropped or otherwise damaged in any way.
5. Do not disassemble the battery charger. If service or repair is required please contact customer service at 1-800-824-0524. Incorrect reassembly may result in a risk of electric shock or fire.
6. To reduce the risk of electrical shock, remove 120 volt or 240 volt AC shore power. Also remove DC battery connections prior to any maintenance or cleaning. Turning off controls will not reduce this risk.

### ⚠ WARNING AVOID SERIOUS INJURY OR DEATH FROM FIRE, EXPLOSION OR ELECTRICAL SHOCK

- Make connection in an open atmosphere free of explosive fumes.
- Make connection in a secure manner that will avoid contact with water.

### ⚠ WARNING – RISK OF EXPLOSIVE GASES.

a) WORKING IN THE VICINITY OF A LEAD-ACID BATTERY IS DANGEROUS. BATTERIES GENERATE EXPLOSIVE GASES DURING NORMAL BATTERY OPERATION. FOR THIS REASON, IT IS OF UTMOST IMPORTANCE THAT EACH TIME BEFORE USING YOUR CHARGER, YOU READ THIS MANUAL AND FOLLOW THE INSTRUCTIONS EXACTLY.

b) To reduce risk of battery explosion, follow these instructions and those published by battery manufacturer and manufacturer of any equipment you intend to use in vicinity of a battery(s). Review cautionary markings on these products.

### PERSONAL PRECAUTIONS

- a) Someone should be within the range of your voice or close enough to come to your aid when working near a Lead-acid battery.
- b) Have plenty of soap and water nearby in case battery acid comes in contact with skin, clothes or eyes.
- c) Wear complete eye protection and clothing protection. Avoid touching eyes while working near battery(s).
- d) If battery acid contacts skin or clothing, wash immediately with soap and water. If acid enters eye, immediately flood eye with running cold water for at least 10 minutes and get medical attention immediately.
- e) NEVER smoke or allow a spark or flame in the vicinity of a battery or engine.

Incorrect assembly may result in electrical shock or fire.

## Important Safety Instructions

f) Be extra cautious to reduce risk of dropping a metal tool onto a battery, it might spark or short-circuit the battery or other electrical hardware that may cause a fire or explosion.

g) Remove all personal metal items such as rings, bracelets, necklaces, watches, and jewelry when working near a battery. A battery can produce a short circuit current high enough to weld a ring or any other metal, causing serious burns.

h) Do not use the battery charger to charge dry cell batteries that are commonly used with home appliances i.e. a cordless power drill battery. These batteries may burst and cause injury to persons and damage to property.

i) NEVER charge a frozen battery.

### PERSONAL SAFETY WHILE PREPARING TO CHARGE BATTERIES

a) Be sure the area around the charger and batteries is well ventilated while the batteries are being charged. Gases can be forcefully blown away using a piece of cardboard or other nonmetallic material as a fan.

b) When cleaning battery terminals wear full eye protection to prevent corrosive material from coming in contact with eyes.

c) Add distilled water (**not tap or bottled water that contain minerals**) in each cell until electrolyte reaches the levels specified by the battery manufacturer. Do not overfill. For batteries without fill caps, carefully follow manufacturer's recharging instructions.

d) Study all battery manufacturer's specific precautions such as removing cell caps while charging and recommended rates of charge.

### GENERAL

- ✓ Provide the required connection from the key switch and the negative DC connection (manufacturers generally use the color purple as the designation for a "key on" lead)
- ✓ Make sure your available amperage from the charging source does NOT EXCEED the rating of the unit.
- ✓ MINIMIZE CONDUCTOR RUNS – Place the ProlsoCharge as close as safely possible to the battery banks to keep wire runs to a minimum.
- ✓ Provide over current protection near the connections to the battery as required in ABYC E-11
- ✓ Ensure the output cables from the ProlsoCharge to the batteries are of a sufficient size to conduct the total potential output current from the ProlsoCharge.
- ✓ Support the cables immediately coming off the ProlsoCharge and ABYC recommends securing cables every 18 inches.

LOCATION - This unit must be located in a dry, well-ventilated area, free from unsecured hardware. Do not mount the unit directly above or below batteries to prevent corrosive electrolyte or gasses from damaging the unit.

LOCATION - MOUNTING - This unit must be mounted securely to an appropriate surface (e.g. plywood bulkhead, cored fiberglass hull structure) and through-bolted if possible.

LOCATION - In addition, the following should be considered when choosing a location:

## Important Safety Instructions

- 1) Service - Remember, there are items on this unit that should be routinely checked (connections, LED Status Center) ensure that there is ample room to address these issues. Also consider space to adequately swing a standard wrench. Contact between a live component and a metallic fuel line can be extremely dangerous. A minimum of 6" of clearance on each side must be maintained.
- 2) Cable Routing - The size of the DC cabling used is dependent upon the proximity to the battery(s) being charged. When deciding on a location, this should be a consideration. Consult the DC cable size table further on in this manual when planning your installation.
- 3) Battery Location - This unit can not be mounted directly above or below a battery due to the corrosive nature of the gasses and electrolyte. Take care to ensure that spillage of electrolyte can be contained in a proper battery box or tray in the event of a leak and that the corrosive gas given off during the use and charge cycles cannot come into contact with the unit.
- 4) Engine Compartment – This unit is ignition protected, so it can be installed in a space containing a gasoline propulsion engine or generator. Mount unit as far from hot exhaust components as possible.

*NOTE: The ProlsoCharge is not intended to be mounted in an open cockpit or deck mounting where weather is a factor.*

See the indicator and connections diagram at the end of this section for more information on the connections and LED functions.

**⚠ CAUTION** if you are replacing an existing battery charger please disconnect the battery charger output cables from the existing charger AND the battery(s). Do not use existing cables if they are not in compliance with the sizes detailed in this manual. If you have any doubt about your ability to fuse and wire this unit correctly PLEASE refer to [www.abyc.com](http://www.abyc.com) for a list of certified electricians in your area that are qualified to perform this installation to the ABYC standards

*All wiring and over current protection (fuses/circuit breakers) must be in accordance with ABYC E-11 AC & DC Electrical Systems on Boats. Recommendations included in this manual are based on these standards. For more information visit [www.abyc.com](http://www.abyc.com).*

Notes on Dual Alternator Installation: In the installation of a dual alternator unit ensure the output wire gauge size is capable of conducting the total current of the two alternators. As an example in the case of the ProlsoCharge 130 2-4 connect to two 120 amp alternators ensure that each of the cables to the 4 battery banks is capable of conducting 240 amps

24 Volt Systems - This manual is written describing 12V installations, for 24V installations always make sure you have a 24V ProlsoCharge and that your batteries are configured as a 24 volt system. Each bank requires a separate 24V positive connection to the unit.

Alternator/Charging Source Size (Amps)	Cable Run (To And From Device)	
	0-4.5 FEET	4.5-12.0 FEET
0-25 A	10 AWG	8 AWG
24-45 A	6 AWG	3 AWG
45-85 A	3 AWG	2 AWG
85-125 A	2 AWG	0 AWG
125-180	0 AWG	2/0 AWG
180-330 A	2/0 AWG	3/0 AWG
Ignition (Key on) & Ground	14 AWG	

## Installation

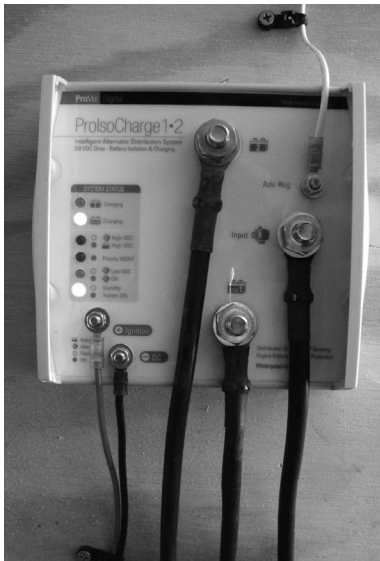

### Mounting

The ProlsoCharge must be securely mounted in order to properly tighten the conductor ends and assist in supporting the large conductors.

Large conductor cables can cause significant stress on the unit. Independently support the conductors within 12 inches of exiting the protective cover.

### Wiring

The following diagram is a typical single-engine, 2 battery bank boat system. Note several features of this system:

- ABYC requires systems of 800 CCA and above to have a battery switch.
- The alternator charging cable also serves as the starter hot lead.
- The alternator output is fused, this is because it is over 40" long OR connected to a non self-limiting alternator.

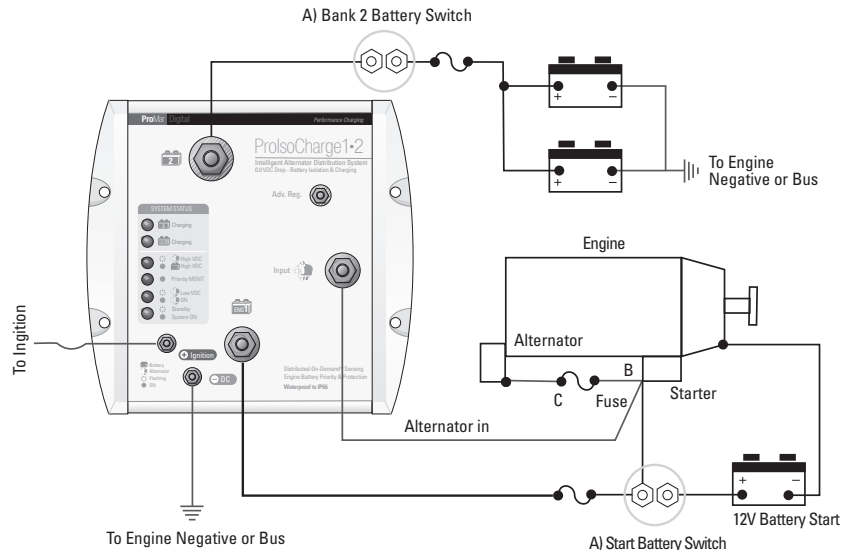

## Installation

Common applications for the ProlsoCharge include:

- ✓ Dual Alternators connected to a single "ALT IN" connection
- ✓ Dual Alternators connected to "ALT 1 IN" and "ALT 2 IN" connection

*NOTE: ALT 1 and BATT 1 connections must originate from the same engine. Mixing alternator inputs and battery outputs from different engines will cause damage and void the warranty*

- ✓ More than 3 battery banks
- ✓ 24 volt applications

The following diagram illustrates a 3 bank, single alternator installation. Note the following:

- The unit requires an ignition (key) on indicator. In most cases the engine supplied lead will be purple in color and will be live when the key is on. A 14 AWG wire is sufficient for this conductor.
- The ProlsoCharge input must come directly off of the alternator to the unit.
 

*NOTE: This unit is NOT rated for starting current. Ensure the unit is NOT installed in such a way that the starter current passes through the unit.*
- A reference ground is required for the unit to operate; this ground must be common to all the batteries connected. A 14 AWG wire is sufficient for this conductor.
- Each battery bank is independently switched prior to the ProlsoCharge. This allows for disconnection of the system in the event of an electrical short not cleared by a fuse or breaker and is also required by ABYC in batteries with 800 or more cold cranking amps.
- The START Batt. has priority for charging, this terminal must be connected to the STARTING battery for proper operation. ALT 1 and BATT 1 connections must originate from the same engine. Mixing Alternator inputs and battery outputs from different engines will cause damage and void the warranty.
- Battery Sensed Alternator or Regulator – This connection is very important if your installation includes an alternator or "smart" regulator that monitors the batteries for state of charge, temperature etc. This connection will ensure the maximum performance of the alternator which will guarantee the ProlsoCharge functions properly.
- Closely follow the wire sizing table at the beginning of this section for all wire

# Installation

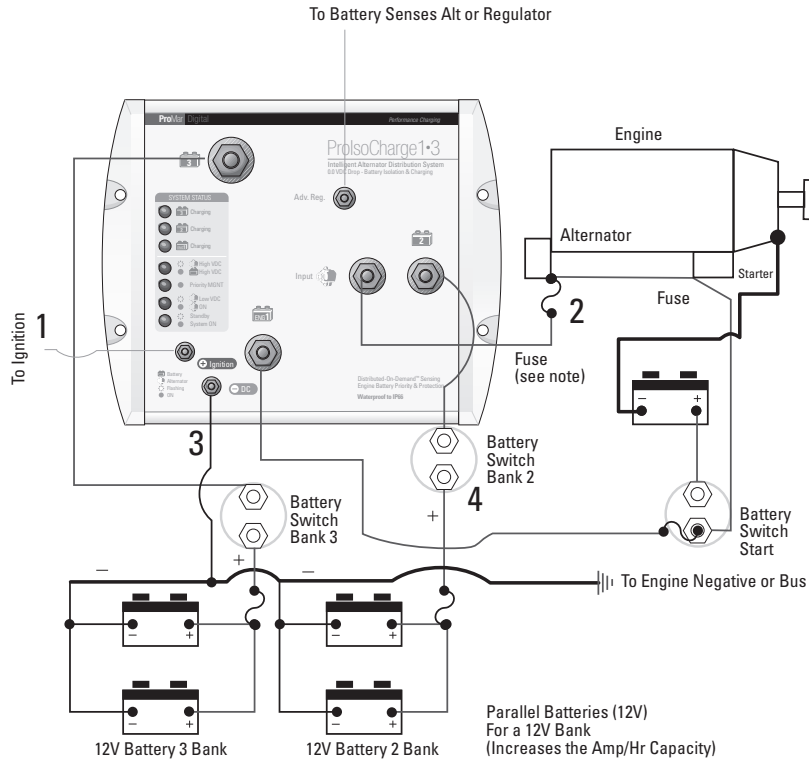

*NOTE: This diagram has all of the elements of the ProIsoCharge models. Additional alternators or charging inputs will follow the same basic configurations.*

# Installation

## Fuses/over current protection

General - The fuses can be up to 150% of the maximum output of the alternator. Each conductor must be fused with the exception of the starting circuit, which is not required to be fused.

Alternator – If the alternator is self-regulating and the conductor is 40 inches or shorter and protected in a sheath or split-loom it does not require a fuse. If its longer than 40 inches a fuse is required.

## Connections

Large AWG conductors require specific tools to make a safe, reliable crimp when attaching ring terminals. It is recommended that pre-terminated cables be purchased or the proper tool be used.

Solder is not an acceptable connection for ring terminals. Soldering causes a brittle connection which will break over time due to the flexibility of the stranded cable and normal vibration in a boat.

When bolting the ring terminal to the stud, ensure the ring terminal is installed first, then the flat washer followed by the lock washer.



## Guarding

The connections that are made to this unit are high amperage. Ensure the protective rubber boots are properly installed, followed by the provided protective cover.

*Note: Rubber boots are removed for clarity.*

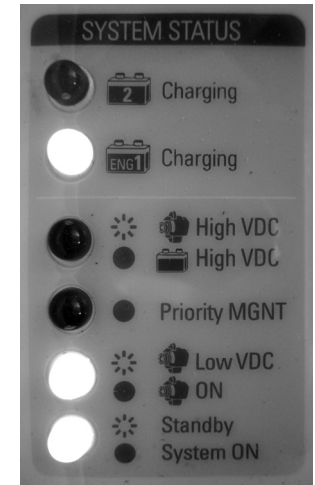

## Start Up

Upon startup, the condition of the LED indicators should resemble this photo. The Engine battery has been given priority, the alternator is charging and the system is on.

## General Operation

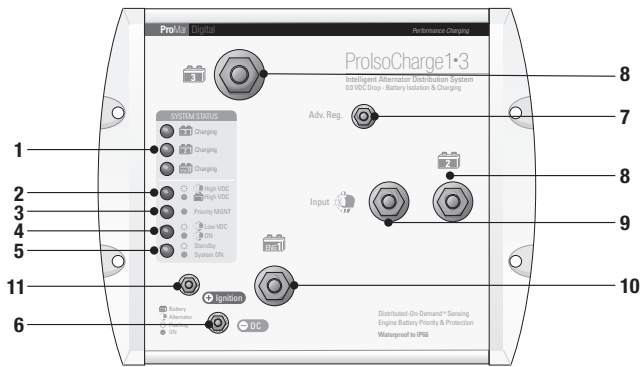

LED indicator Descriptions (See illustration)			
LED Label	LED Color	Function	
1 *Battery 1,2,3 Charging 	Blue	Circuits are active and working normally <i>*The number of battery indicators will be determined by the type of unit which may be 2, 3 or 4 batteries.</i>	
2 High Alternator or Battery Voltage 	Red (flash) Alternator Red (solid) Battery	High alternator voltage (flash) or high battery voltage (solid). In addition a bank LED may be off, indicating which bank is involved.	
3 Priority Management	Red	Priority has been given to one bank, a bank LED will be on, indicating which bank is charging	
4 Alternator Charge State 	Green (solid) Green (flash)	Solid indicates charge level normal (above 13.3 V) Flashing indicates below 13.3 V.	
5 Standby/ON	Blue (solid) Blue (flash)	Solid indicates alternator on. Flash indicates standby or no charge	

Connection Description	
6	Negative - DC Negative Connection
7	Sense – Connection for the remote sense wire from an advanced alternator regulator or battery sensed alternator, if equipped. If you do not have this additional hardware, do not use this connection.
8	Battery 2 & Battery 3 – These connections are for auxiliary battery banks, other than the start.
9	Alternator Input – This is the main “Charge In” connection from an alternator or other source such as a wind generator or battery charger.
10	Start Battery – This terminal senses power for the ProsoCharge unit and ensures that the battery attached to this connection is the priority for charging.
11	Positive Ignition Feed – Connect to an “ignition on/off” connection to indicate that when the key is on, the unit should be working.

## Maintenance

This unit is solid state and requires no constant adjustment or constant attention; however, the following items should be checked:

Maintenance Item	Start Up	Monthly
Verify LED status panel shows no fault condition and indicates normal operation.	✓	
Condition of fuses/breakers check for as-new condition on fuses (e.g. no discoloration or corrosion) and that a breaker will manually trip and reset.	✓	
Check for proper ventilation and that no debris has collected on the fan shroud or items have been improperly stored around the unit.	✓	
Check battery terminal connections (both at battery and the ProsoCharge unit) for corrosion, clean and reconnect immediately upon signs of corrosion.		✓
Per manufacturer’s instructions, check and top off batteries with distilled water. Use of tap or bottled drinking water will damage battery plates due to mineral content.		✓
Check wire condition, overheating due to excessively long or too small conductors will result in hardening of the insulation or even burn marks at connections; If any of these signs exist, immediately remedy the situation by installing the proper conductors.		✓

## Troubleshooting

LED	Color	Function & Fault Analysis
Battery 1,2,3 on-line	Blue	Circuits are active and working normally
High Alternator Voltage Trip	Red (Flash)	High Alternator Voltage - The unit has sensed a voltage exceeding 16V. All banks will be disconnected, all bank LEDs will be out. The alternator or regulator must be repaired. In the event that the voltage drops below 15V the unit will begin normal operation again.
High Output Trip	Red (Solid)	High Output warning (solid). In addition a bank LED may be off, indicating which bank is involved. This fault occurs when the ProIsoCharge senses a bank is charging above 16 volts and attempting to backfeed to another bank. This could be caused by a faulty battery charger. The problem bank will be disconnected and indicated by the bank LED that is NOT lit. Correct the overcharge immediately.
Priority Management	Red	One bank is attempting to discharge another. This can happen when a large load such as an inverter or bowthruster is operating on its connected bank and due to high amperage draw, the neighboring battery banks are being discharged. The ProIsoCharge will isolate the discharged bank and direct charging to that bank only until it reaches 13.3V. The ProIsoCharge will then begin charging normally, beginning with the start battery.
Alternator Charge State	Green (flash)	Flashing indicates below 13.3v. This indicates that the alternator is not functioning properly OR the cable between the ProIsoCharge and the alternator is too small or too long.
	Green (solid)	Solid indicates charge level normal (above 13.3v)
	OFF	Indicates that the alternator is below 10V, and is off
Standby/ON	Blue (solid)	Indicates alternator on
	Blue (flash)	Indicates the ProIsoCharge is in standby mode OR there is no charge

## Warranty

WARRANTY CARD CAN BE REGISTERED AT [WWW.PROMARINER.COM](http://WWW.PROMARINER.COM) or the warranty card included in this manual can be completed and sent to ProMariner by mail.

### PROISOCHARGE ADVANCED DIGITAL CHARGE DISTRIBUTION AND ISOLATION SYSTEM FIVE YEAR WARRANTY

Each ProMariner ProIsoCharge Series Model is guaranteed against defects in material and workmanship for five full years after purchase. Each serial numbered product has an additional repair adjustment provision after the 5 year limited warranty that limits the maximum charge for repair or replacement to 50% of the current list price, plus shipping and handling.

- Warranty and repair adjustment calculated from manufacture date if not registered or proof of purchase within two weeks of sale.
- Warranty void if unauthorized repairs attempted.
- Water damage not covered under warranty
- Customer is responsible for shipping to ProMariner.
- Cosmetic repairs are done at the owner's request and expense.

Purchase or other acceptance of the product shall be on the condition and agreement that Professional Mariner, LLC SHALL NOT BE LIABLE FOR INCIDENTAL OR CONSEQUENTIAL DAMAGES OF ANY KIND. (Some states do not allow the exclusion or limitation of incidental or consequential damages, so the above limitations may not apply to you.) This warranty is made in lieu of all other obligations or liabilities on the part of Professional Mariner. Professional Mariner neither assumes nor authorizes any person for any obligation or liability in connection with the sale of this product.

To make a claim under warranty, go to [www.promariner.com](http://www.promariner.com) and click on the support tab and follow the instructions making sure to identify the product and the problem. If you can not use our online warranty claim registration, please feel free to call ProMariner at the toll free number listed below. Professional Mariner will make its best effort to repair or replace the product, if found defective within the terms of the warranty, within 30 days after return of the product to the company. Professional Mariner will ship the repaired or replaced product back to the purchaser. This warranty gives you specific legal rights, and you may also have other rights, which vary from state to state. This warranty is in lieu of all others expressed or implied.

Factory Service Center & Technical Support  
Professional Mariner, LLC  
200 International Drive, STE 195  
Portsmouth, NH 03801.  
Tel: 1-800-824-0524

Professional Mariner, LLC  
Tel: (603) 433-4440 / Fax: (603) 433-4442